

N75 Mini PCIe

Product Specifications

Issue 1.0 Date 2019-11-05



Copyright © Neoway Technology Co., Ltd 2019. All rights reserved.

No part of this document may be reproduced or transmitted in any form or by any means without prior written consent of Neoway Technology Co., Ltd.

neoway is the trademark of Neoway Technology Co., Ltd.

All other trademarks and trade names mentioned in this document are the property of their respective holders.

Notice

This document provides a guide for users to use N75 Mini PCIe.

This document is intended for system engineers (SEs), development engineers, and test engineers.

THIS GUIDE PROVIDES INSTRUCTIONS FOR CUSTOMERS TO DESIGN THEIR APPLICATIONS. PLEASE FOLLOW THE RULES AND PARAMETERS IN THIS GUIDE TO DESIGN AND COMMISSION. NEOWAY WILL NOT TAKE ANY RESPONSIBILITY OF BODILY HURT OR ASSET LOSS CAUSED BY IMPROPER OPERATIONS.

THE INFORMATION IN THIS DOCUMENT IS SUBJECT TO CHANGE WITHOUT NOTICE DUE TO PRODUCT VERSION UPDATE OR OTHER REASONS.

EVERY EFFORT HAS BEEN MADE IN PREPARATION OF THIS DOCUMENT TO ENSURE ACCURACY OF THE CONTENTS, BUT ALL STATEMENTS, INFORMATION, AND RECOMMENDATIONS IN THIS DOCUMENT DO NOT CONSTITUTE A WARRANTY OF ANY KIND, EXPRESS OR IMPLIED.

Neoway provides customers complete technical support. If you have any question, please contact your account manager or email to the following email addresses:

Sales@neoway.com

Support@neoway.com

Website: <http://www.neoway.com>

Contents

1 About N75 Mini PCIe	1
1.1 Product Overview	1
1.2 Block Diagram	2
1.3 Basic Features	3
2 Compliant Standards	5
3 Application Interfaces	6
3.1 Pin definition	6
3.2 Pin Description	7
3.3 Appearance	10
4 Electric Feature and Reliability	11
4.1 Electric Features	11
4.2 Temperature Features	11
4.3 ESD Protection	12
5 RF Features	13
5.1 Operating Bands	13
5.2 TX Power and RX Sensitivity	14
5.3 GNSS Features	16
6 Mechanical Features	18
6.1 Dimensions	18
6.2 Label	19
6.3 Pack	19
6.4 Storage	20
7 Mounting	21
A Abbreviation	22

Table of Figures

Figure 1-1 Block Diagram	2
Figure 3-1 N75 Mini PCIe pin definition	6
Figure 3-1 N75 Mini PCIe.....	10
Figure 6-1 Dimensions of N75 Mini PCIe.....	18
Figure 6-2 N75 label.....	19
Figure 6-3 Packaging process	19
Figure 7-1 Mini PCIe connector	21

Neoway Confidential

Table of Tables

Table 1-1 Variant and frequency bands.....	1
Table 1-2 Baseband and wireless features of N75 Mini PCIe.....	3
Table 3-1 IO types and level features	7
Table 3-2 Pin Description	7
Table 4-1 Electric features.....	11
Table 4-2 Electric features of N75 Mini PCIe	11
Table 4-3 ESD feature of N51	12
Table 5-1 Operating bands of N75 Mini PCIe	13
Table 5-2 TX RF power of N75 Mini PCIe.....	14
Table 5-3 RX sensitivity of N75-NA/NF/A Mini PCIe	15
Table 5-4 RX sensitivity of N75-EA Mini PCIe.....	15
Table 5-5 GNSS indicators.....	16

About This Document

Scope

This document is applicable to the N75 Mini PCIe series.



Audience

This document is intended for [system engineers \(SEs\)](#), [development engineers](#), and [test engineers](#).

Change History

Issue	Date	Change	Changed By
1.0	2019-11	Initial draft	Dong Liuting

Conventions

Symbol	Indication
	This warning symbol means danger. You are in a situation that could cause fatal device damage or even bodily damage.
	Means the reader be careful. In this situation, you might perform an action that could result in module or product damages.
	Means note or tips for readers to use the module

Related Documents

Neoway_N75 Mini PCIe_Datasheet

Neoway_N75 Mini PCIe_HW_User_Guide

Neoway_N75 Mini PCIe_AT_Command_Mannual

Neoway_N75 Mini PCIe_EVK_User_Guide

Neoway Confidential

1 About N75 Mini PCIe

The N75 Mini PCIe module is an industrial-grade 4G module that is developed on a Qualcomm platform. Its interfaces meet the PCI Express Mini Card 1.2 standard. In addition to the standard interfaces, it also provides various function interfaces for customers. This module is applicable to video surveillance, laptop, in-vehicle devices, wireless routers, and other IoT communications devices.

1.1 Product Overview

N75 Mini PCIe provides variants (excluding the NF variant) that GNSS is optional. You can choose it based on your demands. Table 1-1 lists the bands that each variant supports.

Table 1-1 Variant and frequency bands

Variant	Region	Category	Band	GNSS ¹
NA	North America	Cat4	FDD-LTE: B2, B4, B5, B7, B12, B13, B25, B26, B66, B71 UMTS: B2, B4, B5 GSM/GPRS/EDGE: 850/1900 MHz	Optional
NF	North America	Cat4	FDD-LTE: B2, B4, B5, B7, B12, B13, B14, B25, B26, B66, B71 UMTS: B2, B4, B5 GSM/GPRS/EDGE: 850/1900 MHz	Not support
A	North America	Cat4	FDD-LTE: B2, B4, B5, B12, B66 UMTS: B2, B4, B5	Optional
EA	European Union	Cat4	FDD-LTE: B1, B3, B5, B7, B8, B20, B28 TDD-LTE: B38, B40 UMTS: B1, B5, B8 GSM/GPRS/EDGE: 900/1800 MHz	Optional
JP	Japan	Cat4	FDD-LTE: B1, B3, B8, B18, B19, B26 TDD-LTE: B41 UMTS: B1, B6, B8, B19UMTS: B1, B8 GSM/GPRS/EDGE: 900/1800 MHz	Optional

¹ GNSS is optional for all above variants except NF

1.2 Block Diagram

N75 Mini PCIe consists of the following functionality modules:

- N75 module
- Power management unit
- RF section
- Application interfaces (USIM, PCM, UART, USB)

Figure 1-1 Block Diagram

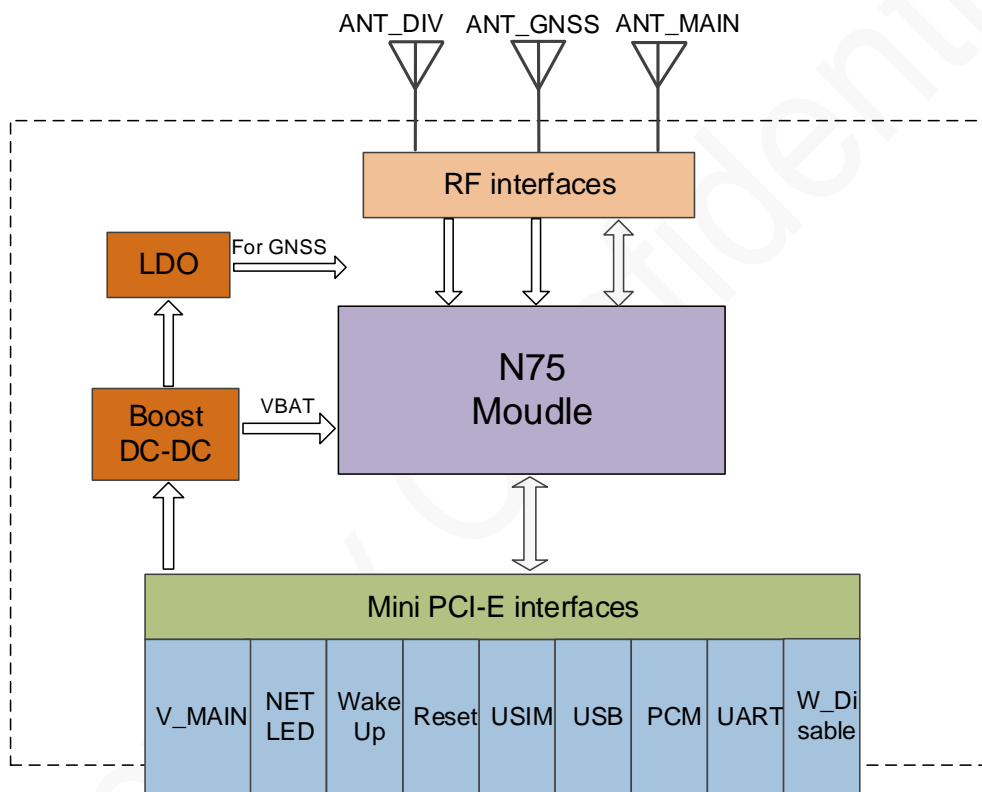

LDO supplies 3.3V for external active GNSS antenna.

1.3 Basic Features

Table 1-2 Baseband and wireless features of N75 Mini PCIe

Parameter	Description
Physical features	Dimensions: 51±0.1 * 30.2±0.1 * 5.3±0.15 mm (H*W*D)
	Weight: around 11.2g
	Package: 52-pin Mini PCIe
Temperature ranges	Operating: -35°C to +75°C Extended: -40°C to +85°C Storage: -45°C to +90°C
Operating voltage	V_MAIN: 3.0V to 3.6V
Operating current ²	Sleep ³ < 20 mA
	Idle < 35mA
	Operating mode ⁴ (LTE networks) Current in data service: about 260mA Current in max. RX power: about 750mA (FDD-LTE), 400mA (TDD-LTE)
MIPS processor	ARM Cortex-A7 processor, 1.3 GHz main frequency
Memory	ROM+RAM: <ul style="list-style-type: none"> • 1Gb+1Gb • 2Gb+1Gb • 2Gb+2Gb
Band	See Table 1-1.
Wireless rate	GPRS: Max 85.6 Kbit/s(DL) / Max 85.6 Kbit/s(UL) EDGE: Max 236.8Kbps(DL) / Max 236.8Kbps(UL) WCDMA: DC-HSPA+, Max 42Mbps(DL)/Max 5.76Mbps(UL) FDD-LTE: non-CA cat4, Max 150 Mbps(DL)/Max 50 Mbps (UL) TDD-LTE: non-CA cat4, Max 130 Mbps(DL)/Max 35 Mbps(UL)
Transmit power	GSM850: +33dBm (Power Class 4) EGSM900: +33dBm (Power Class 4) DCS1800: +30dBm (Power Class 1) PCS1900: +30dBm (Power Class 1) EDGE 850MHz: +27dBm (Power Class E2) EDGE 900MHz: +27dBm (Power Class E2)

² For operating currents of different network modes in different states, see the N75 Mini PCIe HW Test Report.

³ To use the sleep mode, ensure that the software supports it and the USB interface is disconnected on hardware.

⁴ Current in operating mode indicates the current during data communication. For currents of other network modes and bands, see N75 Mini PCIe Current Test Report.

	EDGE1800MHz: +26dBm (Power Class E2) EDGE1900MHz: +26dBm (Power Class E2) UMTS: +24 dBm (Power Class 3) LTE: +23dBm (Power Class 3)
	2G/3G/4G antenna, 4G diversity antenna, GNSS antenna 50Ω impedance
Application Interfaces	One UART interface One USIM interface, 1.8V/3V One USB2.0 high-speed interface One PCM interface
Data	PPP, RNDIS, ECM, RMNET
Protocol	TCP, UDP, MQTT, FTP/FTPS, HTTP/HTTP(S), SSL, TLS
Certification approval	FCC, PTCRB, AT&T*, CE-R*, GCF*, RoHS*, NCC*, RCM*

2 Compliant Standards

N75 Mini PCIe complies with the following standards:

- 3GPP TS 07.07 *AT command set for GSM Mobile Equipment (ME)*
- YD 1214-2006 *Technical requirement of 900/1800MHz TDMA Digital Cellular Mobile Telecommunication Network General Packet Radio Service (GPRS)Equipment: Mobile Stations*
- YD 1215-2006 *Testing Methods of 900/1800MHz TDMA Digital Cellular Mobile Telecommunication Network General Packet Radio Service (GPRS)Equipment: Mobile Stations*
- YD 1032-2000 *Limits and Measurement Methods of Electromagnetic Compatibility for 900/1800MHz Digital Cellular Telecommunications System Part1: Mobile Station and Ancillary Equipment*
- YD/T 2220-2011 *Technical Requirement and test method of WCDMA/GSM(GPRS) dual-mode digit mobile user equipment (phase 4)*
- Ministry of Industry and Information Technology PRC, *Measures for the Network Access Management of Telecommunication Equipment (2014 Amendment)*
- GB4943.1-2011 *Information technology equipment - Safety - Part 1: General requirements*
- GB/T22450.1-2008 *Limits and measurement methods of electromagnetic compatibility for 900/1800MHz TDMA digital cellular telecommunications system - Part 1: Mobile station and ancillary equipment*
- CNCA-O7C-031:2007*Rules for Compulsory Certification of Telecommunication Equipment Telecommunication Terminal Equipment*
- 3GPP TS GSM Specification Set
- 3GPP TS WCDMA Specification Set
- 3GPP TS LTE Cat4 4G Specification Set

3 Application Interfaces

3.1 Pin definition

N75 Mini PCIe provides 52 pins and their definitions meet the standard of Mini PCI Express. Figure 3-1 shows the pin definitions.

Figure 3-1 N75 Mini PCIe pin definition

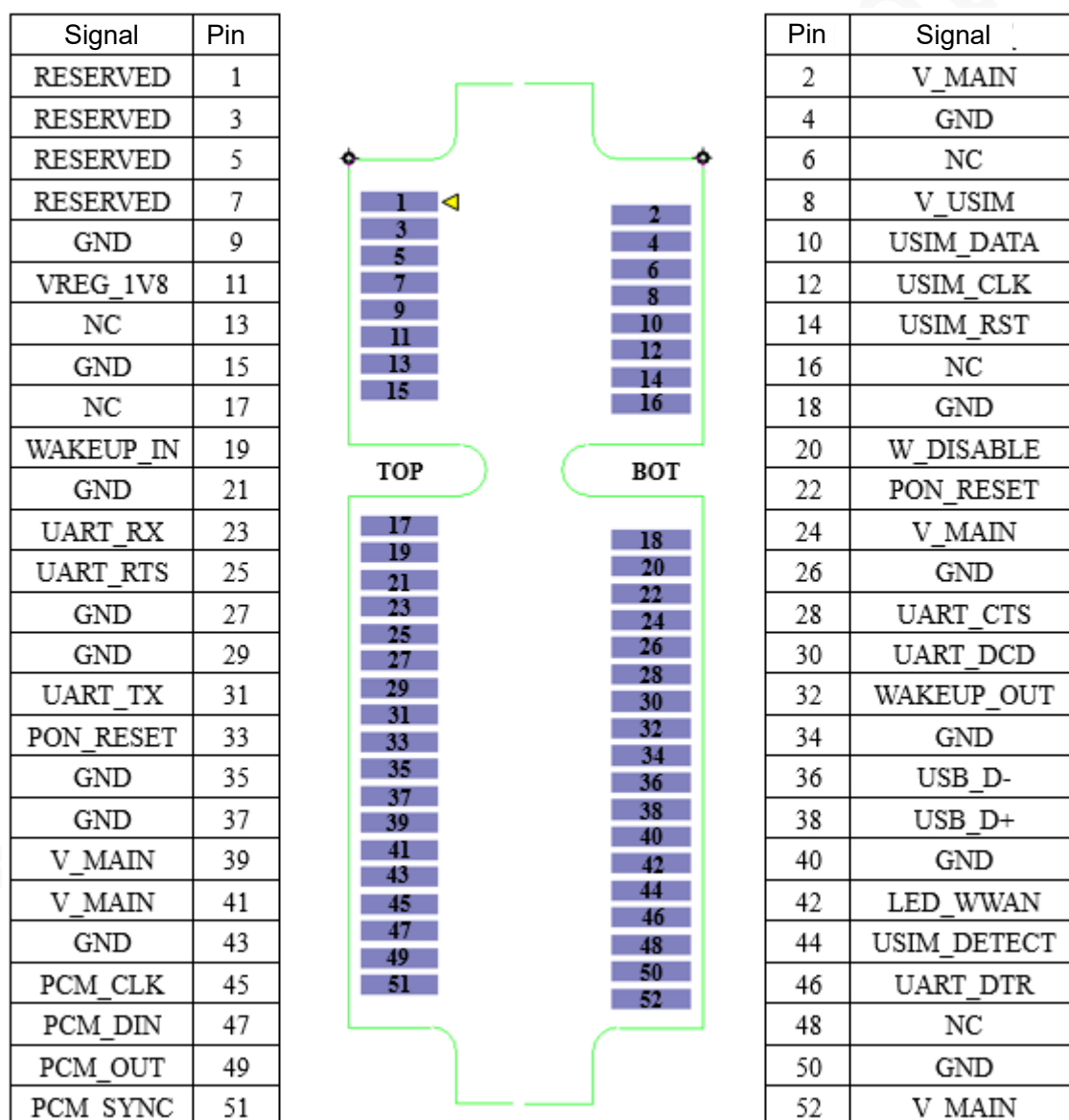

3.2 Pin Description

The following table shows the IO types and level features of the N75 Mini PCIe.

Table 3-1 IO types and level features

IO Type	
B	Digital input/output
DO	Digital output
DI	Digital input
OC	Open circuit
PO	Power output
PI	Power supply input
AI	Analog input
AO	Analog output
Level Feature	
P1	USIM interface voltage, compatible with 1.8V/3V 1.8V USIM card: $V_{IH}=1.26V\sim 2.1V$, $V_{IL}=-0.3V\sim 0.36V$, $V_{OH}=1.44V\sim 1.8V$, $V_{OL}=0V\sim 0.4V$ 3V USIM card: $V_{IH}=2V\sim 3.15V$, $V_{IL}=-0.3V\sim 0.57V$, $V_{OH}=2.28V\sim 2.85V$, $V_{OL}=0V\sim 0.4V$
P3	1.8V IO voltage $V_{IH\ min}=1.2V$, $V_{IL\ max}= 0.3V$ $V_{OH\ min}=1.35V$, $V_{OL\ max}= 0.45V$

Table 3-2 Pin Description

Pin	Signal	I/O	Function	Level Feature	Remarks
1	RESERVED				
2	V_MAIN	PI	Main power supply input	$V_{min}=3.0V$ $V_{max}=3.6V$	Supply at most 2.5A current
3	RESERVED				
4	GND		Ground		
5	RESERVED				
6	NC				
7	RESERVED				
8	V_USIM	PO	USIM card power supply output	P1	The module is compatible with 1.8V and 3V USIM cards.

					Leave this pin floating if it is not used.
9	GND		Ground		
10	USIM_DATA	B	USIM card data IO	P1	Leave this pin floating if it is not used.
11	VREG_1V8	PO	1.8V power output	Vnorm=1.8V Imax=50mA	Used only for level shifting. Leave this pin floating if it is not used.
12	USIM_CLK	DO	USIM clock output	P1	Leave this pin floating if it is not used.
13	NC				
14	USIM_RST	DO	USIM card reset	P1	Leave this pin floating if it is not used.
15	GND		Ground		
16	NC				
17	NC				
18	GND		Ground		
19	WAKEUP_IN	DI	Sleep mode control	P3	Leave this pin floating if it is not used.
20	W_DISABLE	DI	Disable communications	RF P3	A low level triggers the ON status. Leave this pin floating if it is not used.
21	GND		Ground		
22	PON_RESET	DI	Module reset input	P3	Triggered by a low level
23	UART_RX	DI	UART data receive	P3	Leave this pin floating if it is not used.
24	V_MAIN	PI	Main power supply input	Vmin=3.0V Vmax=3.6V	Same as pin 2
25	UART_RTS	DO	Request to send	P3	Leave this pin floating if it is not used.
26	GND		Ground		
27	GND		Ground		
28	UART_CTS	DI	Clear to send	P3	Leave this pin floating if it is not used.
29	GND		Ground		
30	UART_DCD	DO	UART carrier	P3	Leave this pin floating if it is not used.

			detection			is not used.
31	UART_TX	DI	Sleep mode control	P3		Leave this pin floating if it is not used.
32	WAKEUP_OUT	DO	Sleep indication	status P3		Leave this pin floating if it is not used.
33	PON_RESET	DI	Module reset input	P3		Leave this pin floating if it is not used.
34	GND		Ground			
35	GND		Ground			
36	USB_D-	IO	USB data negative signal			In compliance with USB2.0
37	GND		Ground			
38	USB_D+	IO	USB data positive signal			In compliance with USB2.0
39	V_MAIN	PI	Main power supply input	Vmin=3.0V Vmax=3.6V		Same as pin 2
40	GND		Ground			
41	V_MAIN	PI	Main power supply input	Vmin=3.0V Vmax=3.6V		Same as pin 2
42	LED_WWAN	OC	Network indicator	status		Leave this pin floating if it is not used.
43	GND		Ground			
44	USIM_DETECT	DI	USIM card detection	P3		Leave this pin floating if it is not used.
45	PCM_CLK	IO	PCM clock signal	P3		Leave this pin floating if it is not used.
46	UART_DTR					
47	PCM_DIN	DI	PCM data input	P3		Leave this pin floating if it is not used.
48	NC					
49	PCM_DOUT	DO	PCM data output	P3		Leave this pin floating if it is not used.
50	GND		Ground			
51	PCM_SYNC	IO	PCM synchronization signal	frame P3		Leave this pin floating if it is not used.
52	V_MAIN	PI	Main power supply input	Vmin=3.0V Vmax=3.6V		Same as pin 2

3.3 Appearance

Figure 3-1 N75 Mini PCIe

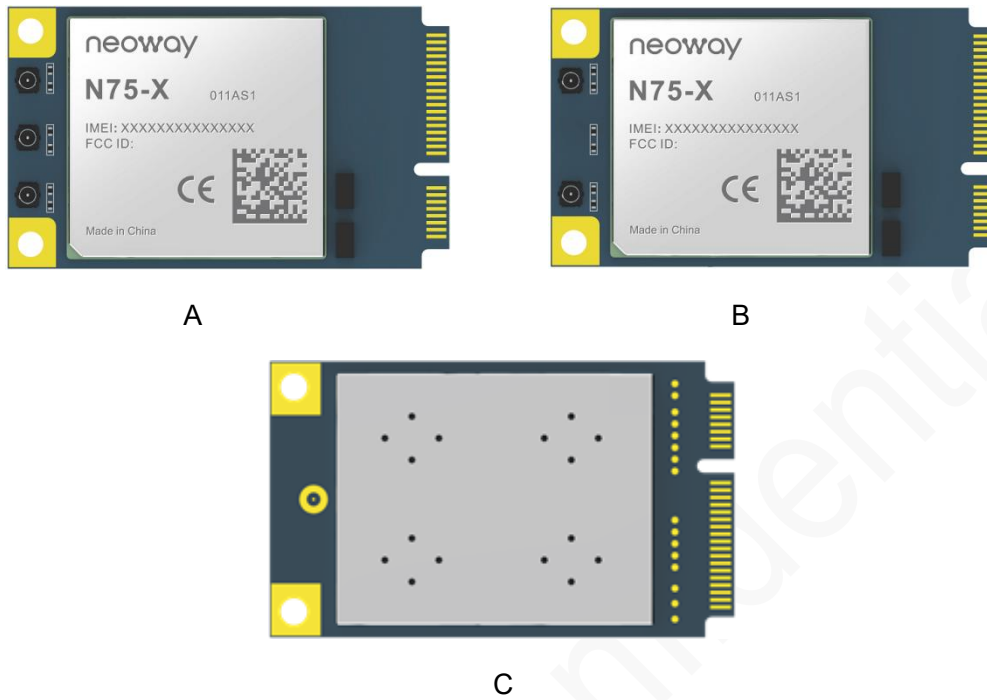

- N75 Mini PCIe includes two variants:
 - A: supporting diversity receiving and GNSS function
 - B: supporting diversity receiving but not supporting GNSS function
 - C: Bottom view of N75 Mini PCIe
- The actual products might be a little bit different from the above figures.

4 Electric Feature and Reliability

4.1 Electric Features

Table 4-1 Electric features

Status		Minimum Value	Typical Value	Maximum Value
V_MAIN	V _{in}	3.0V	-	3.6V
	I _{in}	-	-	2.5A



If the voltage is lower than the threshold, the module might fail to start. If the voltage is higher than the threshold or there is a voltage burst during the startup, the module might be damaged permanently.

If you use LDO or DC-DC to supply power for the module, ensure that it outputs at least 2.5A current. When the module works at maximum power in the GSM/GPRS system, the transient peak current might reach the peak. Add a large capacitor near the VBAT pin to enhance the capability to output continuous current and avoid voltage drop.

4.2 Temperature Features

Table 4-2 Electric features of N75 Mini PCIe

Status	Minimum Value	Typical Value	Maximum Value
Operating	-35°C	25°C	75°C
Extended	-40°C		85°C
Storage	-45°C		90°C



If the module works in an environment of -30°C to -40°C or 75°C to 85°C, RF performance might be beyond the requirements of 3GPP. This does not affect the running of the module. The RF performance will meet the 3GPP standard after the temperature reaches the operating range.

4.3 ESD Protection

Electronics need to pass ESD tests. The following table shows the ESD capability of key pins of this module. It is recommended to add ESD protection based on the application scenarios to ensure product quality when designing a product.

Testing environment:

Humidity 45% Temperature 25°C

Table 4-3 ESD feature of N51

Testing Point	Contact Discharge	Air Discharge
V_MAIN	±8kV	±15kV
GND	±8kV	±15kV
ANT	±8kV	±15kV
Cover	±8kV	±15kV
Others	±2kV	±4kV

5 RF Features

5.1 Operating Bands

Table 5-1 Operating bands of N75 Mini PCIe

Operating Bands	Uplink	Downlink
GSM850	824~849MHz	869~894MHz
GSM900	880~915MHz	925~960MHz
DCS1800	1710~1784MHz	1805~1880MHz
PCS1900	1850~1910MHz	1930~1990MHz
UMTS B1	1920~1980MHz	2110~2170MHz
UMTS B2	1850~1910MHz	1930~1990MHz
UMTS B4	1710~1755MHz	2110~2155MHz
UMTS B5	824~849MHz	869~894MHz
UMTS B6	830~840MHz	875~885MHz
UMTS B8	880~915MHz	925~960MHz
UMTS B19	830~845MHz	875~890MHz
FDD-LTE B1	1920~1980MHz	2110~2170MHz
FDD-LTE B2	1850~1910MHz	1930~1990MHz
FDD-LTE B3	1710~1785MHz	1805~1880MHz
FDD-LTE B4	1710~1755MHz	2110~2155MHz
FDD-LTE B5	824~849MHz	869~894MHz
FDD-LTE B7	2500~2570MHz	2620~2690MHz
FDD-LTE B8	880~915MHz	925~960MHz
FDD-LTE B12	699~716MHz	728~746MHz
FDD-LTE B13	777~787MHz	746~757MHz
FDD-LTE B14	788~798MHz	758~768MHz
FDD-LTE B18	815~830MHz	860~875MHz
FDD-LTE B19	830~845MHz	875~890MHz
FDD-LTE B20	832~862MHz	791~821MHz

FDD-LTE B25	1850~1915MHz	1930~1995MHz
FDD-LTE B26	814~849MHz	859~894MHz
FDD-LTE B28	703~748MHz	758~803MHz
FDD-LTE B66	1710~1780MHz	2110~2200MHz
FDD-LTE B71	617~652MHz	663~698MHz

5.2 TX Power and RX Sensitivity

Table 5-2 TX RF power of N75 Mini PCIe

Band	TX Max Power	TX Min Power
GSM850	33 dBm+2/-2dBm	5dBm+5/-5dBm
GSM900	33 dBm+2/-2dBm	5dBm+5/-5dBm
DCS1800	30dBm+2/-2dBm	5dBm0/-5dBm
PCS1900	30dBm+2/-2dBm	5dBm0/-5dBm
UMTS B1	24dBm +1/-3dBm	<-50dBm
UMTS B2	24dBm +1/-3dBm	<-50dBm
UMTS B4	24dBm +1/-3dBm	<-50dBm
UMTS B5	24dBm +1/-3dBm	<-50dBm
UMTS B6	24dBm +1/-3dBm	<-50dBm
UMTS B8	24dBm +1/-3dBm	<-50dBm
UMTS B19	24dBm +1/-3dBm	<-50dBm
FDD-LTE B1	23 dBm+2/-2dBm	<-44dBm
FDD-LTE B2	23dBm+2/-2dBm	<-44dBm
FDD-LTE B3	23dBm+2/-2dBm	<-44dBm
FDD-LTE B4	23dBm+2/-2dBm	<-44dBm
FDD-LTE B5	23dBm+2/-2dBm	<-44dBm
FDD-LTE B7	23dBm+2/-2dBm	<-44dBm
FDD-LTE B8	23dBm+2/-2dBm	<-44dBm
FDD-LTE B12	23dBm+2/-2dBm	<-44dBm
FDD-LTE B13	23dBm+2/-2dBm	<-44dBm
FDD-LTE B14	23dBm+2/-2dBm	<-44dBm
FDD-LTE B18	23dBm+2/-2dBm	<-44dBm

FDD-LTE B19	23dBm+2/-2dBm	<-44dBm
FDD-LTE B20	23dBm+2/-2dBm	<-44dBm
FDD-LTE B25	23dBm+2/-2dBm	<-44dBm
FDD-LTE B26	23dBm+2/-2dBm	<-44dBm
FDD-LTE B28	23dBm+2/-2dBm	<-44dBm
TDD-LTE B38	23dBm+2/-2dBm	<-44dBm
TDD-LTE B40	23dBm+2/-2dBm	<-44dBm
FDD-LTE B66	23dBm+2/-2dBm	<-44dBm
FDD-LTE B71	23dBm+2/-2dBm	<-44dBm

Table 5-3 RX sensitivity of N75-NA/NF/A Mini PCIe

Band	Main RX Sensitivity	DIV RX Sensitivity	Main+DIV RX Sensitivity
GSM850	<-108 dBm	/	<-108 dBm
PCS1900	<-108dBm	/	<-108dBm
UMTS B2	<-110 dBm	/	<-110 dBm
UMTS B4	<-108dBm	/	<-108dBm
UMTS B5	<-110 dBm	/	<-110 dBm
FDD-LTE B2	<-98 dBm	<-99 dBm	<-101 dBm
FDD-LTE B4	<-98 dBm	<-98.5 dBm	<-101 dBm
FDD-LTE B5	<-98 dBm	<-99 dBm	<-102 dBm
FDD-LTE B7	<-95.5 dBm	<-97 dBm	<-98.5 dBm
FDD-LTE B12	<-96.5 dBm	<-98 dBm	<-101.5 dBm
FDD-LTE B13	<-96.5 dBm	<-98 dBm	<-101.5 dBm
FDD-LTE B14	<-96.5 dBm	<-98 dBm	<-101.5 dBm
FDD-LTE B25	<-98 dBm	<-98 dBm	<-101.5 dBm
FDD-LTE B26	<-98 dBm	<-99.5 dBm	<-102 dBm
FDD-LTE B66	<-97 dBm	<-97.5 dBm	<-100 dBm
FDD-LTE B71	<-95.5 dBm	<-97 dBm	<-100.5 dBm

Table 5-4 RX sensitivity of N75-EA Mini PCIe

Band	Main RX Sensitivity	DIV RX Sensitivity	Main+DIV RX Sensitivity
GSM900	<-108dBm	/	<-108dBm
DCS1800	<-108dBm	/	<-108dBm

UMTS B1	<-110 dBm	/	<-110 dBm
UMTS B5	<-110 dBm	/	<-110 dBm
UMTS B8	<-110 dBm	/	<-110 dBm
FDD-LTE B1	<-97.5 dBm	<-98 dBm	<-100.5 dBm
FDD-LTE B3	<-96.5 dBm	<-98 dBm	<-100 dBm
FDD-LTE B5	<-97.5 dBm	<-99 dBm	<-102 dBm
FDD-LTE B7	<-95 dBm	<-96.5 dBm	<-97.5 dBm
FDD-LTE B8	<-97.5 dBm	<-98 dBm	<-101.5 dBm
FDD-LTE B20	<-97 dBm	<-98.5 dBm	<-101 dBm
FDD-LTE B28	<-97.5 dBm	<-98.5 dBm	<-102 dBm
TDD-LTE B38	<-96.5 dBm	<-96.5 dBm	<-98 dBm
TDD-LTE B40	<-96.5 dBm	<-97.5 dBm	<-99 dBm



All values above were obtained in the lab. In actual applications, there be a difference because of network environments.

5.3 GNSS Features

Table 5-5 GNSS indicators

Changes	Parameter
GPS L1 operating frequency	1575.42±1.023MHz
GLONASS operating frequency	1597.5~1605.9 MHz
BDS operation frequency	1559.1~1563.1 MHz
Tracking sensitivity	-160dBm (GPS)/-159.5 dBm (GLONASS)/TBD(BDS)
Acquisition sensitivity	-144dBm (GPS)/-143.5 dBm (GLONASS)
Positioning precision (in air)	< 3m (CEP50)
Hot start (in air)	<2.5s
Cold start (in air)	<35s
Update frequency	1Hz by default
CNRin/CNRout	3dB
Max. positioning altitude	18000m

Max. positioning speed	515m/s
Max. positioning acceleration	4g
GNSS data type	NMEA-0183
GNSS antenna type	Passive/active antenna



Tracking sensitivity, acquisition sensitivity, and re-acquisition sensitivity were obtained in a signaling test on SPIRENT6300 and they are the maximum values of multiple tests on samples. No external LNA or active antenna was used in the test.

6 Mechanical Features

6.1 Dimensions

Figure 6-1 Dimensions of N75 Mini PCIe

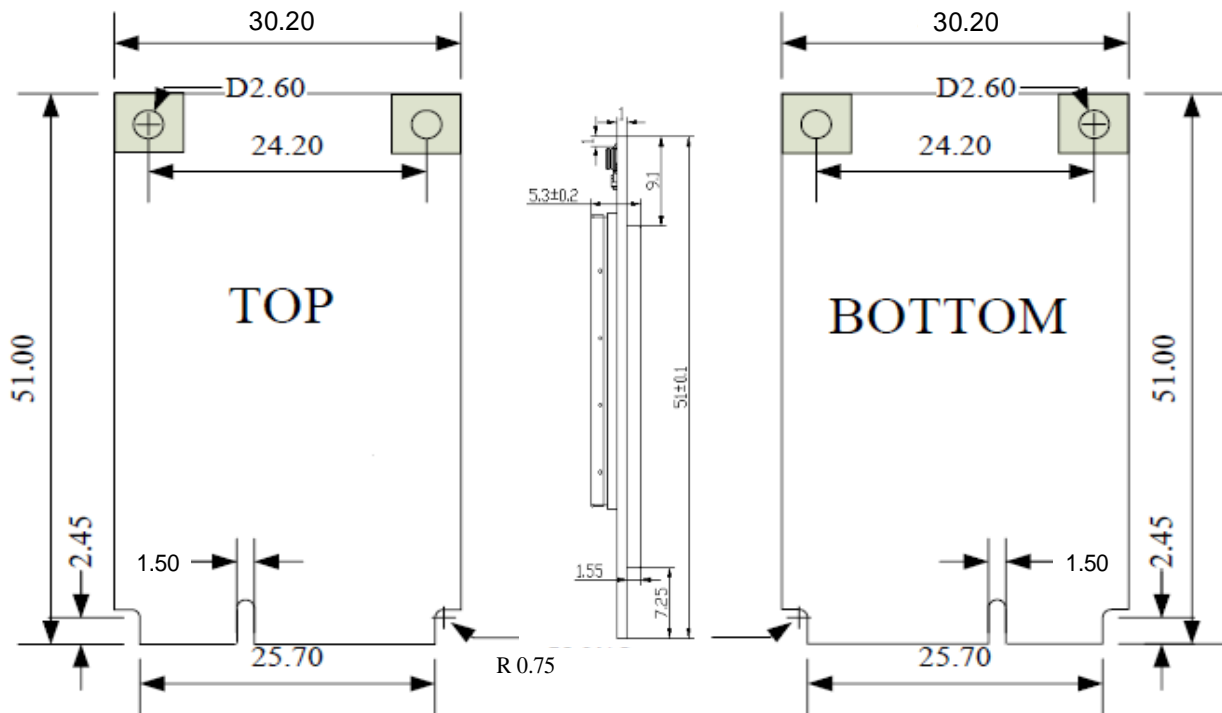

The unit is mm.

6.2 Label

The label is made of materials that are deformation-resistant, fade-resistant, and high-temperature-resistant and it can endure high temperature up to 260°C.

Figure 6-2 N75 label



- The picture above is only for reference.
- The silk-screen printing must be clear. No blur is allowed.
- The material and surface finishing must comply with RoHS directives.

6.3 Pack

N75 Mini PCIe modules are packaged in sealed vacuum bags with dryer, humidity card, and tray on delivery to guarantee a long shelf life. Follow the same package method again in case of opened for any reason.

Figure 6-3 Packaging process

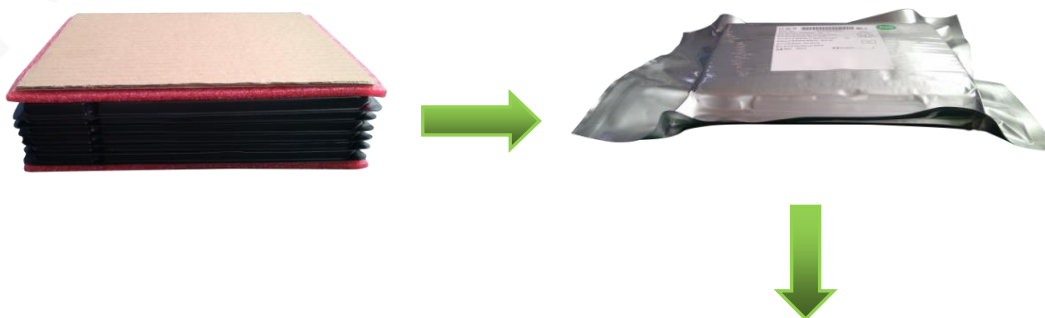



6.4 Storage

- Temperature: 20°C to +26°C
- Humidity: 40% to 60%
- Period: 120 days

7 Mounting

N75 Mini PCIe adopts the standard PCI Express Mini Card 1.2 interfaces and can be mounted to a Mini PCIe connector. It is recommended to use 679100002 from Molex. The following figure shows its dimensions.

Figure 7-1 Mini PCIe connector

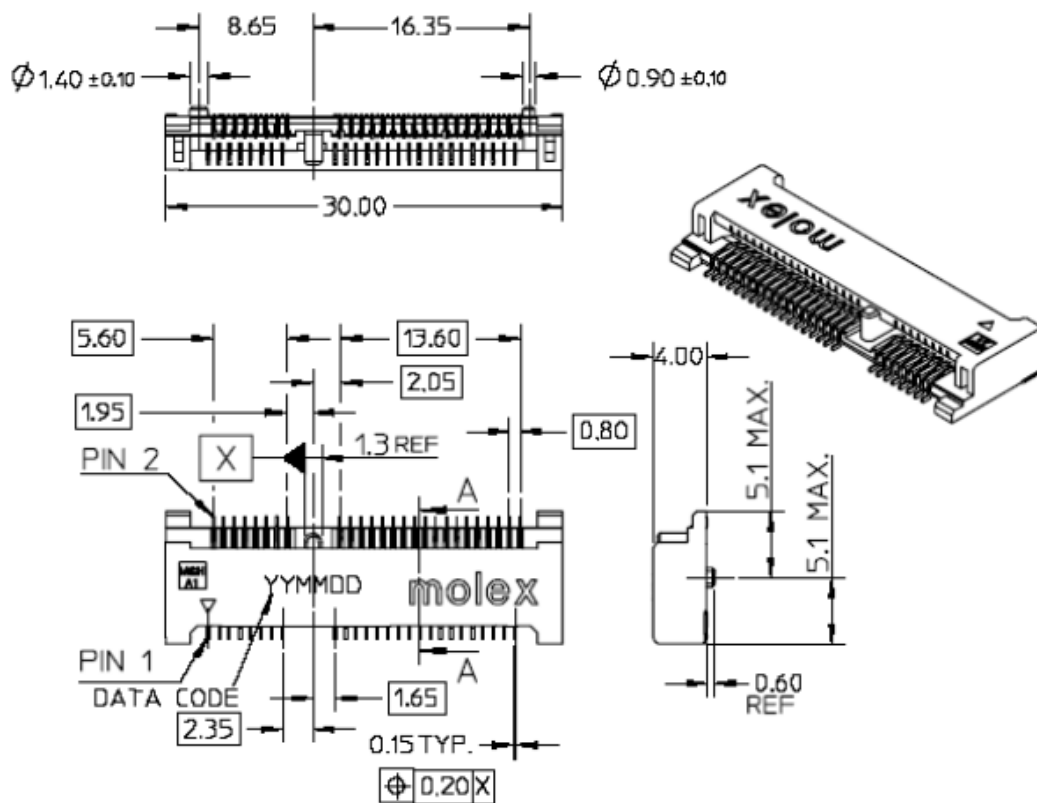

A Abbreviation

Abbreviation	English Full Name
DC-HSPA+	Dual-carrier HSPA+
EDGE	Enhanced Data Rates for GSM Evolution
EV-DO	Evolution-data Optimized
FDD	Frequency Division Duplex
GNSS	Global Navigation Satellite System
HSPA+	High-Speed Packet Access
LGA	Land Grid Array
LTE	Long-Term Evolution
PCB	Printed Circuit Board
RF	Radio Frequency
UART	Universal Asynchronous Receiver-Transmitter
USIM	Universal Subscriber Identity Module
UMTS	Universal Mobile Telecommunications System
USB	Universal Serial Bus
WCDMA	Wide-band Code Division Multiple Access
PCM	Pulse Code Modulation