

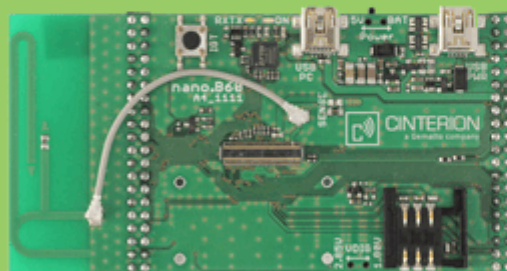

CINTERION
a Gemalto company

Starter Kit B60 User Guide

Version: 02
DocId: Starter_Kit_B60_v02



User Guide

User Guide:	Starter Kit B60 User Guide
Version:	02
Date:	2012-03-12
DocId:	Starter_Kit_B60_v02
Status	Confidential / Released

GENERAL NOTE

THE USE OF THE PRODUCT INCLUDING THE SOFTWARE AND DOCUMENTATION (THE "PRODUCT") IS SUBJECT TO THE RELEASE NOTE PROVIDED TOGETHER WITH PRODUCT. IN ANY EVENT THE PROVISIONS OF THE RELEASE NOTE SHALL PREVAIL. THIS DOCUMENT CONTAINS INFORMATION ON CINTERION PRODUCTS. THE SPECIFICATIONS IN THIS DOCUMENT ARE SUBJECT TO CHANGE AT CINTERION'S DISCRETION. CINTERION WIRELESS MODULES GMBH GRANTS A NON-EXCLUSIVE RIGHT TO USE THE PRODUCT. THE RECIPIENT SHALL NOT TRANSFER, COPY, MODIFY, TRANSLATE, REVERSE ENGINEER, CREATE DERIVATIVE WORKS; DISASSEMBLE OR DECOMPILE THE PRODUCT OR OTHERWISE USE THE PRODUCT EXCEPT AS SPECIFICALLY AUTHORIZED. THE PRODUCT AND THIS DOCUMENT ARE PROVIDED ON AN "AS IS" BASIS ONLY AND MAY CONTAIN DEFICIENCIES OR INADEQUACIES. TO THE MAXIMUM EXTENT PERMITTED BY APPLICABLE LAW, CINTERION WIRELESS MODULES GMBH DISCLAIMS ALL WARRANTIES AND LIABILITIES. THE RECIPIENT UNDERTAKES FOR AN UNLIMITED PERIOD OF TIME TO OBSERVE SECRECY REGARDING ANY INFORMATION AND DATA PROVIDED TO HIM IN THE CONTEXT OF THE DELIVERY OF THE PRODUCT. THIS GENERAL NOTE SHALL BE GOVERNED AND CONSTRUED ACCORDING TO GERMAN LAW.

Copyright

Transmittal, reproduction, dissemination and/or editing of this document as well as utilization of its contents and communication thereof to others without express authorization are prohibited. Offenders will be held liable for payment of damages. All rights created by patent grant or registration of a utility model or design patent are reserved.

Copyright © 2012, Cinterion Wireless Modules GmbH

Trademark Notice

Microsoft and Windows are either registered trademarks or trademarks of Microsoft Corporation in the United States and/or other countries. All other registered trademarks or trademarks mentioned in this document are property of their respective owners.

Contents

0	Document History	4
1	Introduction	5
1.1	Supported Products	5
1.2	Related Documents	5
1.3	Scope of delivery	5
2	Product Concept	6
2.1	Key Features at a Glance	7
2.2	System Overview	7
3	Step-By-Step Startup	8
4	Interface Description	11
4.1	USB Interfaces	11
4.1.1	USB-PC Connection	11
4.1.2	USB Power Supply	11
4.2	Board-to-Board Connector	11
4.3	Status LEDs	11
4.4	SIM Card Holder	12
4.5	Antenna Connector	12
4.6	Switches	13
4.6.1	Ignition	13
4.6.2	Power Supply Switch	13
4.6.3	VDIG Switch	14
4.7	2x40-Pin Connector	15
5	Appendix: Schematics and Placement	16

0 Document History

New document: "Starter Kit B60 User Guide" Version **02**

Chapter	What is new
5	Added placement for Starter Kit B60 to Appendix.

New document: "Starter Kit B60 User Guide" Version 01

Chapter	What is new
---	Initial document setup.

1 Introduction

The Starter Kit B60 is a simple and easy-to-use adapter board designed to quickly test and evaluate basic functionalities of the supported evaluation modules.

The purpose of this document¹ is to guide you through the process of connecting the hardware and getting started with the module evaluation.

[Chapter 2](#) introduces the product concept, including key features and system overview, [Chapter 3](#) gives a short step-by-step guide to connect and power-up the Starter Kit B60 and [Chapter 4](#) describes the Starter Kit's interfaces in some more detail. The Appendix finally contains the Starter Kit's schematics (see [Chapter 5](#)).

1.1 Supported Products

This User Guide applies to the following products:

- BG2 module
For BG2 ordering numbers see [\[2\]](#).
- BGS2 evaluation module
 - BGS2-E ordering number: L30960-N2201-A100
 - BGS2-W ordering number: L30960-N2211-A100

1.2 Related Documents

- [1] BG2 / BGS2 AT Command Set
 [2] BG2 / BGS2 Hardware Interface Description

1.3 Scope of delivery

Table 1: Starter Kit B60 delivery package

Quantity	Description
1	Starter Kit B60
1	Hirose antenna cable 50mm

The BG2 and BGS2 evaluation modules for use with the Starter Kit B60 are not included in the scope of delivery. Also not included are the standard mini USB cables (USB A to USB Mini-B 5 pin) to connect the Starter Kit B60 to a PC and/or another external power supply.

¹ The document is effective only if listed in the appropriate Release Notes as part of the technical documentation delivered with your Cinterion wireless module.

2 Product Concept

Figure 1 shows the interfaces of the Starter Kit B60.

Top view

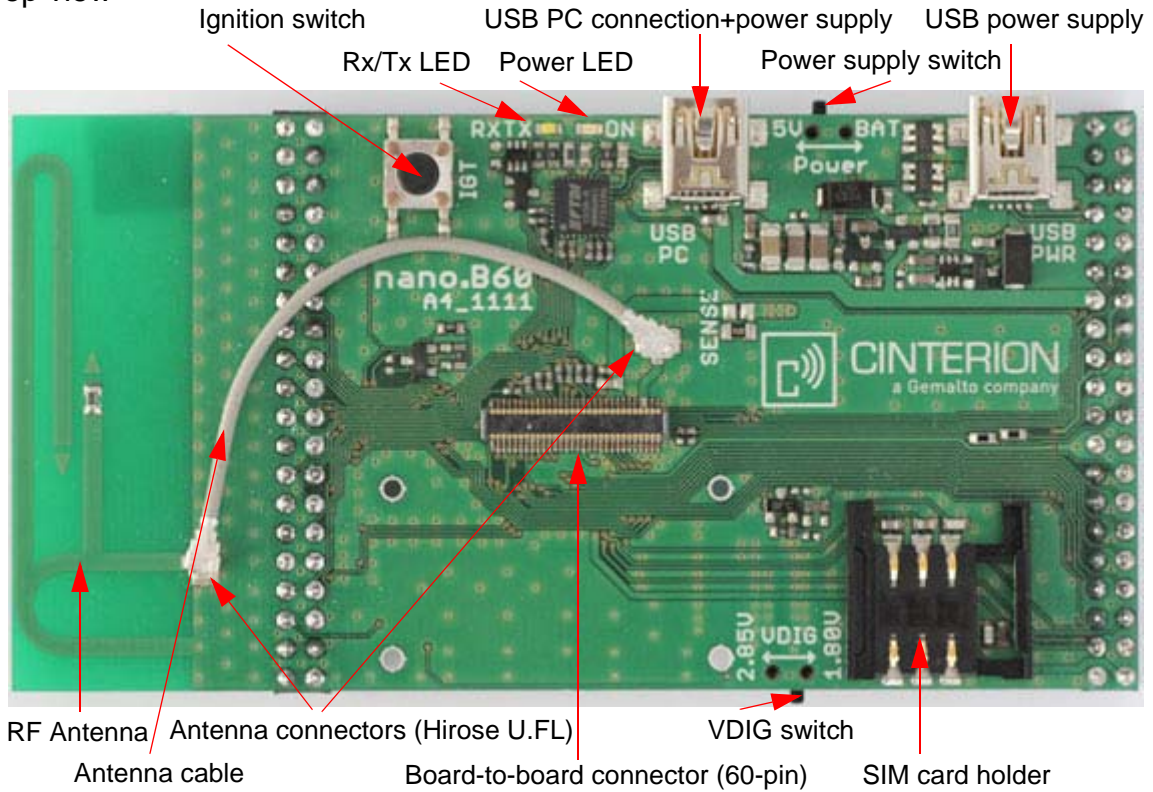

Bottom view

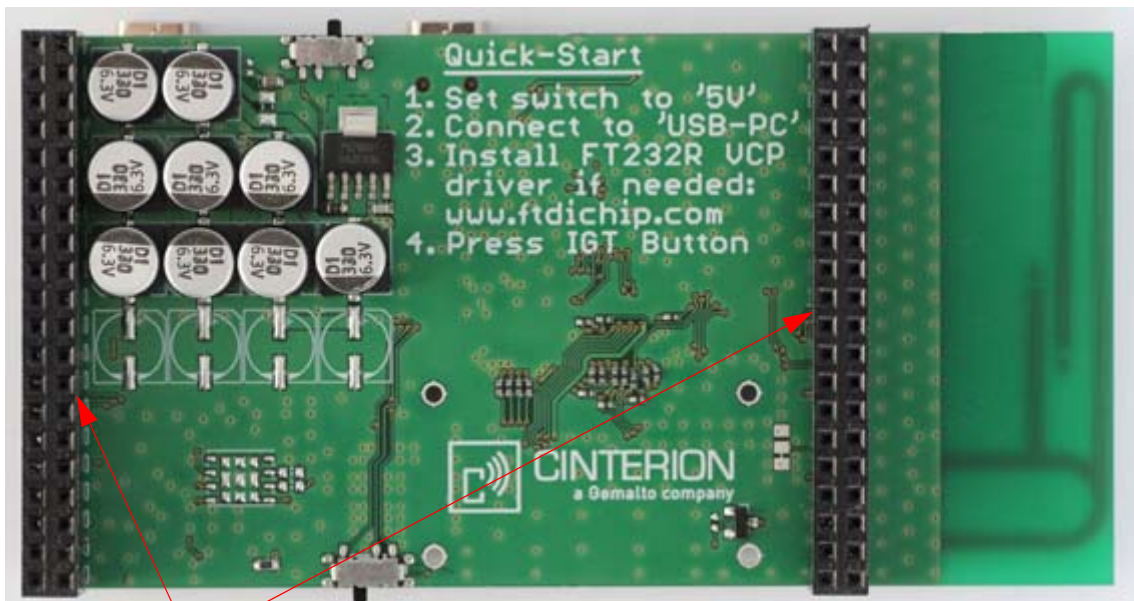

Figure 1: Starter Kit B60 overview

2.1 Key Features at a Glance

Table 2: Key features at a glance

Feature	Implementation
Module interface	Direct connection via 60-pin board to board connector Supports BG2 and BGS2 evaluation modules For module features please refer to [2].
Power supply	5V via USB interface and / or 5V external supplied through 2x40-pin connector
Antenna interface	Implemented dual band RF antenna: - Optimized for 850/900/1800MHz - Tunable for 1900MHz
SIM interface	Supported SIM cards: 3V, 1.8V
Serial interfaces	1 serial interface accessible via USB VCP Maximum baud rate 230,400bps
Signal indication	2 LEDs for On/Off and (virtual) Rx/Tx lines
Signal accessibility	All module signals accessible via 2x40-pin connector
Dimensions	100mm x 50mm (length x width)

2.2 System Overview

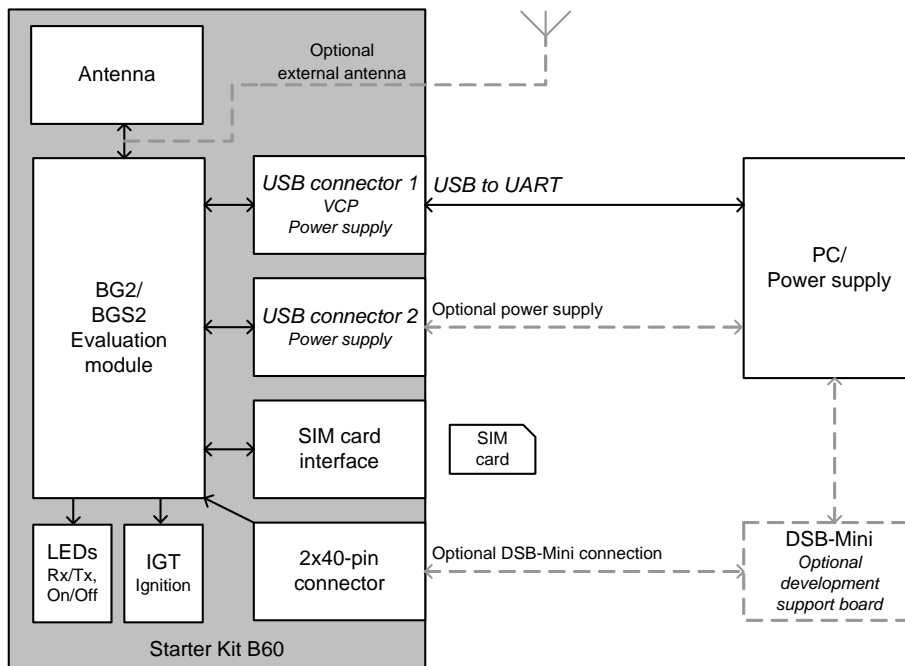

Figure 2: Starter Kit B60 system overview

3 Step-By-Step Startup

To set up the Starter Kit B60 please follow the below step-by-step instructions. The mentioned interfaces - connectors and switches - are illustrated in [Chapter 2](#). A more detailed description of these interfaces can be found in [Chapter 4](#):

- Download and extract the virtual COM port (VCP) driver. The virtual COM port (VCP) driver will cause the Starter Kit B60 - connected to a PC via USB - to appear as an additional COM port available on the PC. For details on the USB-to-UART bridge see [Chapter 4](#). The VCP driver can be downloaded free of charge from Future Technology Devices International Ltd. (<http://www.ftdichip.com/Drivers/VCP.htm>).
- Set the power supply switch to 5V and the voltage domain (VDIG) switch to 1.8V (delivery default).
- Connect the integrated antenna as shown in [Figure 3](#).
- Mount the BG2 or BGS2 evaluation module by plugging the evaluation module onto the Starter Kit B60's 60-pin board-to-board connector.
- Insert the SIM as shown in [Figure 3](#).



Figure 3: Starter Kit B60 with evaluation module and SIM

- Connect the Starter Kit B60's USB-PC interface to a PC using a standard USB mini cable (USB A to USB Mini-B 5 pin).
- Install the VCP driver software.
Under Windows the Starter Kit B60 is automatically recognized as a new hardware device and the *Found New Hardware Wizard* opens to help install software for the new device - "FT232 USB UART". Click the box *Installation from a list or specific location* box and navigate to the folder containing the extracted VCP driver files. Follow the on screen instructions.
Now, the "FT232 USB UART" device is installed as a USB serial port and the *Found New Hardware Wizard* will open again for this new device - "USB Serial Port". Repeat browsing to the folder containing the extracted VCP driver files to install software for the "USB Serial Port". Follow the on screen instructions.

The newly installed hardware device, i.e., the ASC0 interface of the evaluation module on the Starter Kit B60, is now available via a "USB Serial Port" in the port list of the Windows Device Manager.

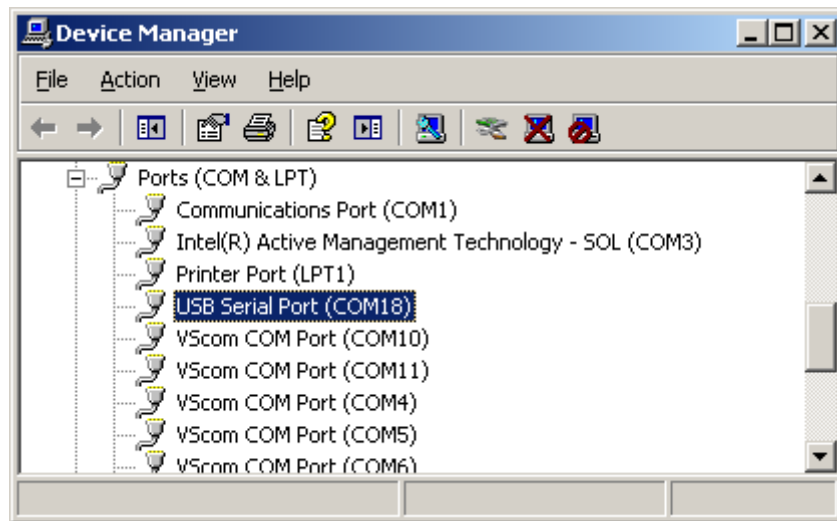

Figure 4: Serial USB Port in Device Manager

It is recommended to change the latency timer for this COM port to 3ms: Right-click on the "USB Serial Port" to open the *Port Properties* window. Select the *Port Settings* tab and press the *Advanced* button to open the window for the *BM options* including latency timer.

- Start a terminal program (e.g. Hyperterminal) to connect to the "USB Serial Port" (COM18). It is recommended to use the following connection settings:

- Bits per second: 115200
- Data bits: 8
- Parity: None
- Stop bits:1
- Flow control: Hardware

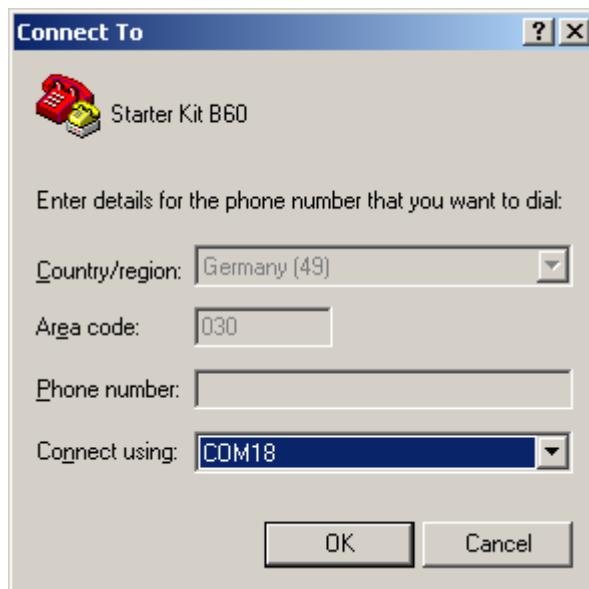

Figure 5: Connect to USB Serial Port

- Press the *Ignition* button on the Starter Kit B60. A blue LED indicates the On state. The Starter Kit B60 should now be connected.

- Check the mounted evaluation module's release version using the AT command ATI. For a complete AT Command Set description see [1]. This includes AT commands to configure the communication interface.

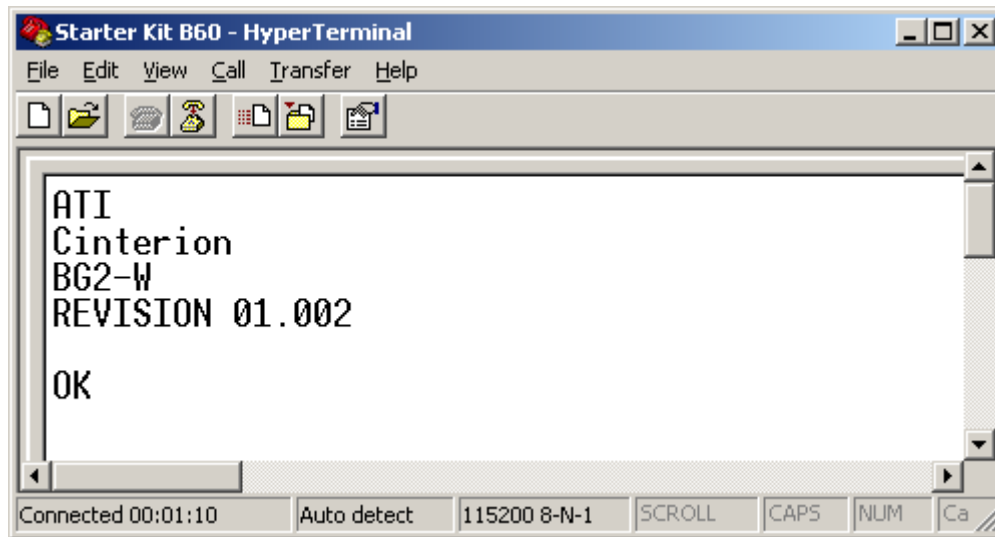

Figure 6: Communication over USB Serial Port

Apart from the serial ASC0 interface lines accessible via USB-to-UART bridge and VCP the other signal lines of the evaluation module are also available - by means of the 2x40-pin connector mounted onto an optional development support board, the DSB-Mini. For details on the available lines please refer to [Section 4.7](#).

4 Interface Description

4.1 USB Interfaces

4.1.1 USB-PC Connection

The Starter Kit B60 features a USB to 8-line UART bridge in order to connect the evaluation module via USB Virtual COM Port (VCP) to a PC. All available module data rates up to 230,400bps are supported.

A specific VCP driver, available from Future Technology Devices International Ltd. (<http://www.ftdichip.com/Drivers/VCP.htm>), needs to be installed and configured on the PC side.

If the Starter Kit B60 operates standalone, i.e., without being connected via the 2x40-pin connector to an external application, this VCP is always active and the only communication channel to the module.

However, the module's ASC0 signals are at the same time also wired to the 2x40-pin connector (see [Section 4.7](#)). In case the Starter Kit B60 is mounted on the optional DSB-Mini, the VCP is deactivated (reset) automatically - the USB-to-UART bridge releases the ASC0 signal lines so the serial communication can be continued through the 2x40pin connector.

The evaluation module's ASC1 signal lines are only connected to the 2x40-pin connector and are not usable while the VCP is active in standalone operation mode.

4.1.2 USB Power Supply

Through the USB-PC connection described above the Starter Kit B60 is supplied with 5V/500mA.

In addition, the Starter Kit B60's second USB interface serves as a further power supply in case of increased power consumption during GPRS Class 10 data transfer and/or frail supplies (e.g., long cables). The second USB interface is for power supply purposes only - there are no evaluation module signal lines connected to this additional USB interface.

4.2 Board-to-Board Connector

The BG2 and BGS2 evaluation modules are mounted to the Starter Kit B60 via the 60-pin board-to-board connector.

4.3 Status LEDs

The Starter Kit B60 features two status LEDs indicating the evaluation module's power on/off state (blue) as well as the current data transfer (Rx/Tx) state (white).

4.4 SIM Card Holder

The Starter Kit B60 has a card holder on its top side for a SIM to be inserted. The SIM card holder supports normal card operation, but does not support the SIM card detection functionality. The evaluation module's card detection line is connected to the 2x40-pin connector only in order to support card detection on the optional DSB-Mini.

The bottom side of the Starter Kit B60 is prepared for a component SIM. The footprint may be used to implement component SIM solutions for evaluation purposes.

4.5 Antenna Connector

The PCB RF antenna integrated into the Starter Kit B60 supports dual band and is by delivery default optimized for 850MHz, 900MHz and 1800MHz. The higher frequency path can be tuned to 1900MHz by removing the 0Ω resistor R27.

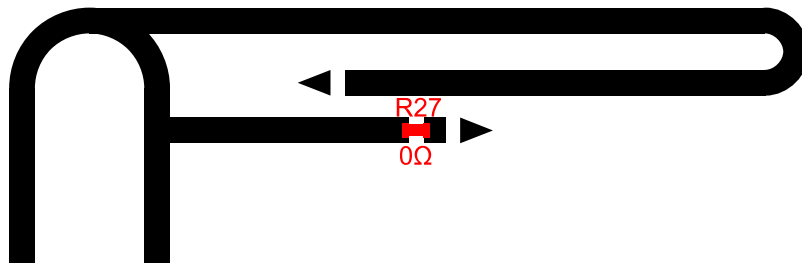

Figure 7: Antenna tuning option

Please note that the RF antenna may be detuned somehow, if largish ground planes are placed directly beneath. In such a case, it is possible to connect an external antenna to the Starter Kit B60 via the Hirose U-FL connector. An external antenna might be useful, if the Starter Kit B60 is mounted onto the optional DSB-Mini and the antenna performance is to be evaluated.

4.6 Switches

4.6.1 Ignition

The *Ignition* button is used to switch on the evaluation module plugged onto the Starter Kit B60.

To switch the module off the AT comand AT^SMSO should be used. Alternatively, the USB power supply can be unplugged.

4.6.2 Power Supply Switch

The Starter Kit B60 has a switch to select the power supply path:

- 5V (default)
The 5V power supply path collects the supply from the USB interfaces on the Starter Kit B60 and the 5V supply from the 2x40-pin connector. A post LDO regulates the module’s operating voltage down to 3.8V.
- Battery
The battery power supply path provides a direct power source on the 2x40pin connector without additional circuitry except the switch resistance (~20mΩ).

If the Starter Kit B60 operates standalone, the switch must be set to “5V” to supply the module through the 5V power supply path.

Only if the Starter Kit B60 is mounted onto the optional DSB-Mini and the evaluation module is supplied by an external battery connected to the DSB-Mini, must the switch be set to “BAT”.

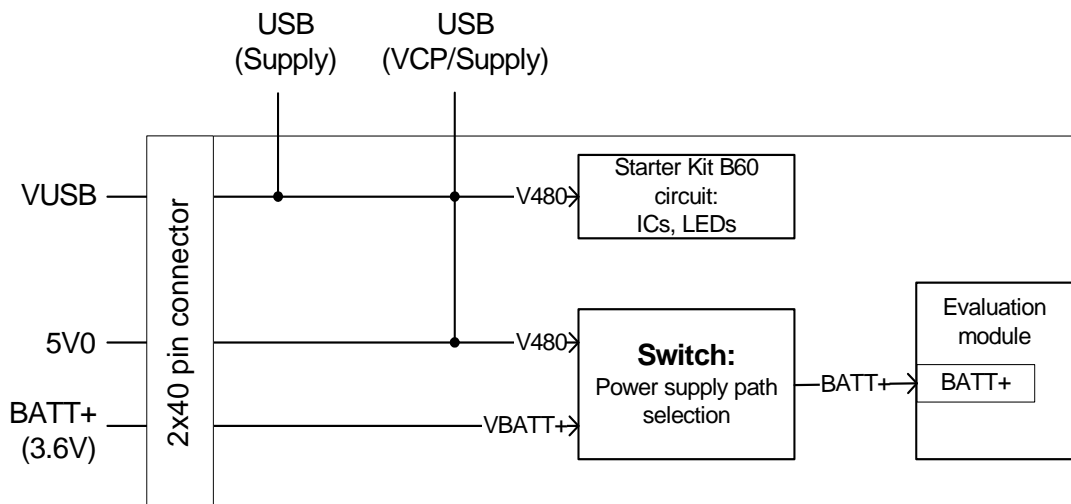

Figure 8: Power supply path selection

4.6.3 VDIG Switch

The Starter Kit B60 has a switch to select the voltage level for a number of signals (detailed in [\[2\]](#)):

- 1.80V (default)
The VDIG signal is connected to the V180 line, i.e., the concerned signals start up with a 1.80V voltage level.
- 2.85V
The VDIG signal is connected to the V285 line, i.e., the concerned signals start up with a 2.85V voltage level.

The implemented USB-to-UART bridge level shifters are adjusted automatically by this switch and the IO signals on the 2x40-pin connector are adjusted accordingly.

This switch has no impact, if the Starter Kit B60 is operated standalone.

4.7 2x40-Pin Connector

All module signals are accessible by means of the 2x40-pin connector. This connector also serves a few additional signals for operation control between the Starter Kit B60 and an optional development support board (DSB-Mini) as well as for additional power supply.

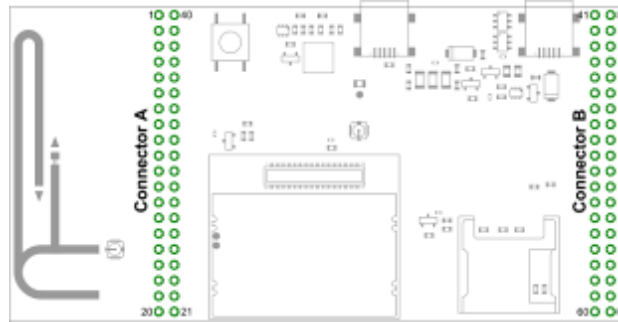

Figure 9: Two 40-pin connectors on Starter Kit B60 top view

Table 3: 2x40-pin connector assignment on Starter Kit B60 (top view)

Connector A				Connector B			
Not connected	1	40	Not connected	BATT+	41	80	BATT+
Not connected	2	39	Not connected	GND	42	79	Do not use
Not connected	3	38	Not connected	AGND	43	78	GND
Not connected	4	37	Not connected	Not connected	44	77	VUSB (supply)
Not connected	5	36	Not connected	Not connected	45	76	VDIG
Not connected	6	35	Not connected	V180	46	75	Not connected
GPIO9/I2CDAT	7	34	GPIO10/I2CCLK	5V0 (main power)	47	74	VMIC
Not connected	8	33	DCD0	EPP	48	73	EPN
EMERG_RST	9	32	CTS1	Not connected	49	72	Not connected
RXD1	10	31	CTS0	MICP	50	71	MICN
RXD0	11	30	RTS1	Not connected	51	70	Not connected
TXD1	12	29	DTR0	Not connected	52	69	Not connected
TXD0	13	28	RTS0	GPIO10/I2CCLK	53	68	GPIO1/DTR0
ADC1	14	27	DSR0	GPIO9/I2CDAT	54	67	GPIO2/DCD0
Not connected	15	26	RING0	GPIO8	55	66	GPIO3/DSR0
GPIO6/PWM2	16	25	Not connected	GPIO7/PWM1	56	65	GPIO4/ FAST_SHTDWN
GPIO5/LED	17	24	VDDL	GPIO6/PWM2	57	64	GPIO5/LED
PWR_IND	18	23	IGT	CCCLK	58	63	CCRST
GND	19	22	GND	CCIO	59	62	CCIN
GND	20	21	GND	CCVCC	60	61	CCGND

5 Appendix: Schematics and Placement

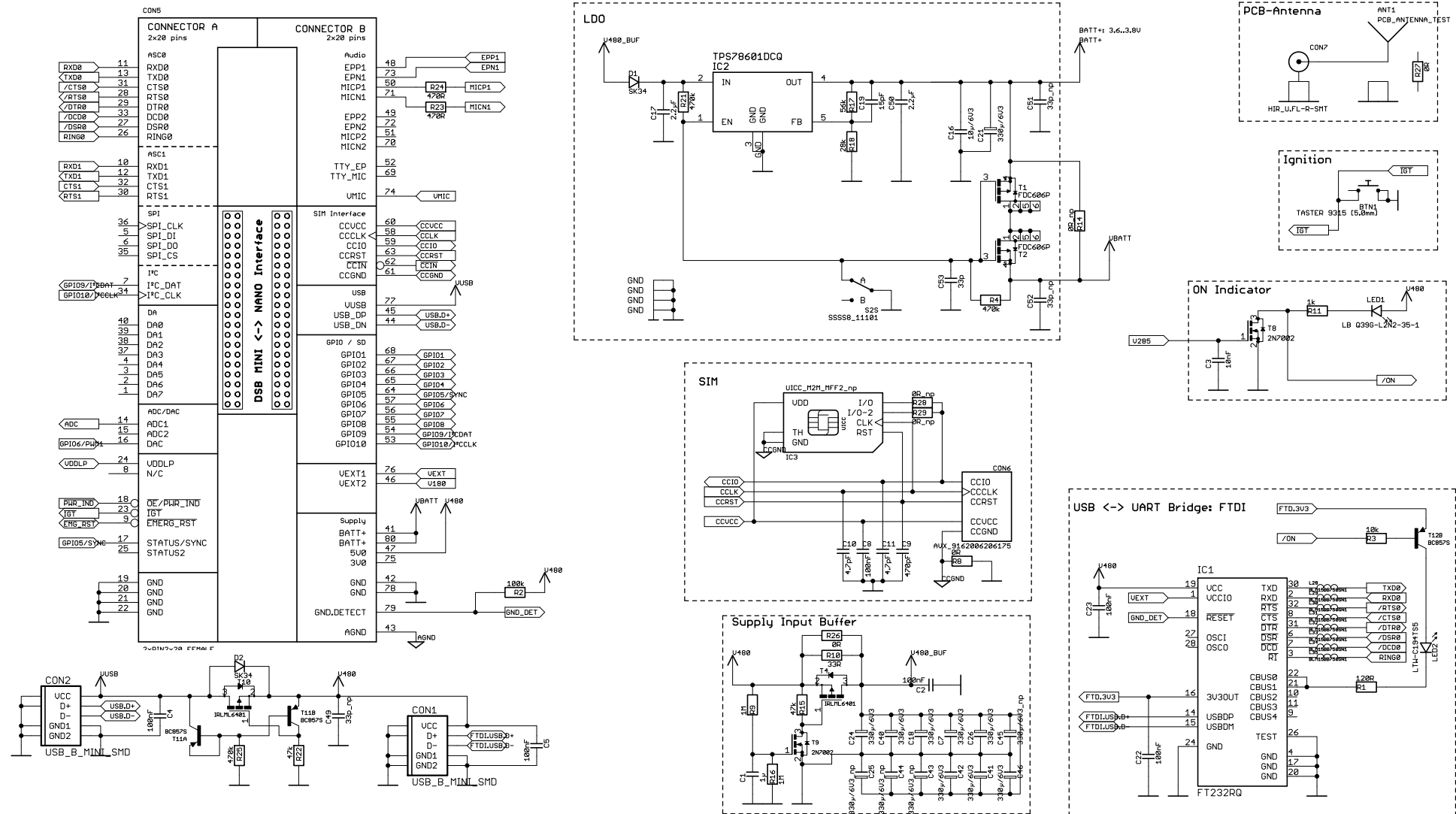

Figure 10: Schematics, Page 1

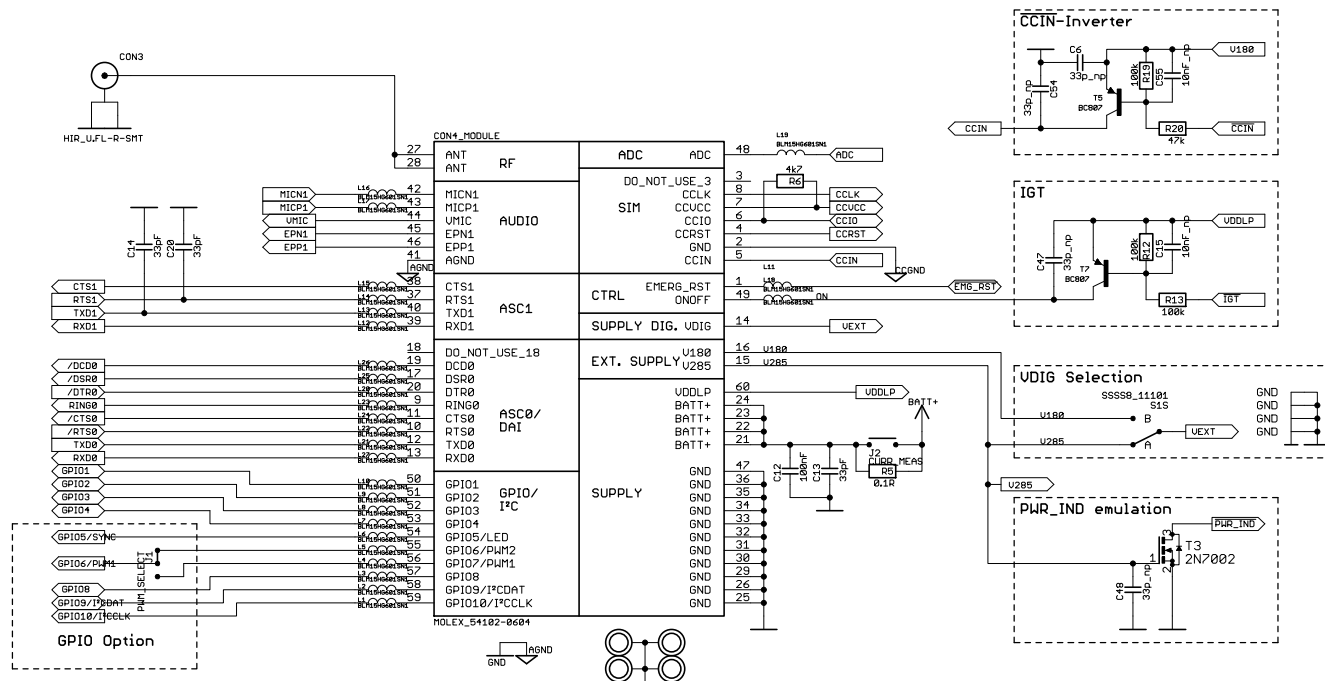

Figure 11: Schematics, Page 2

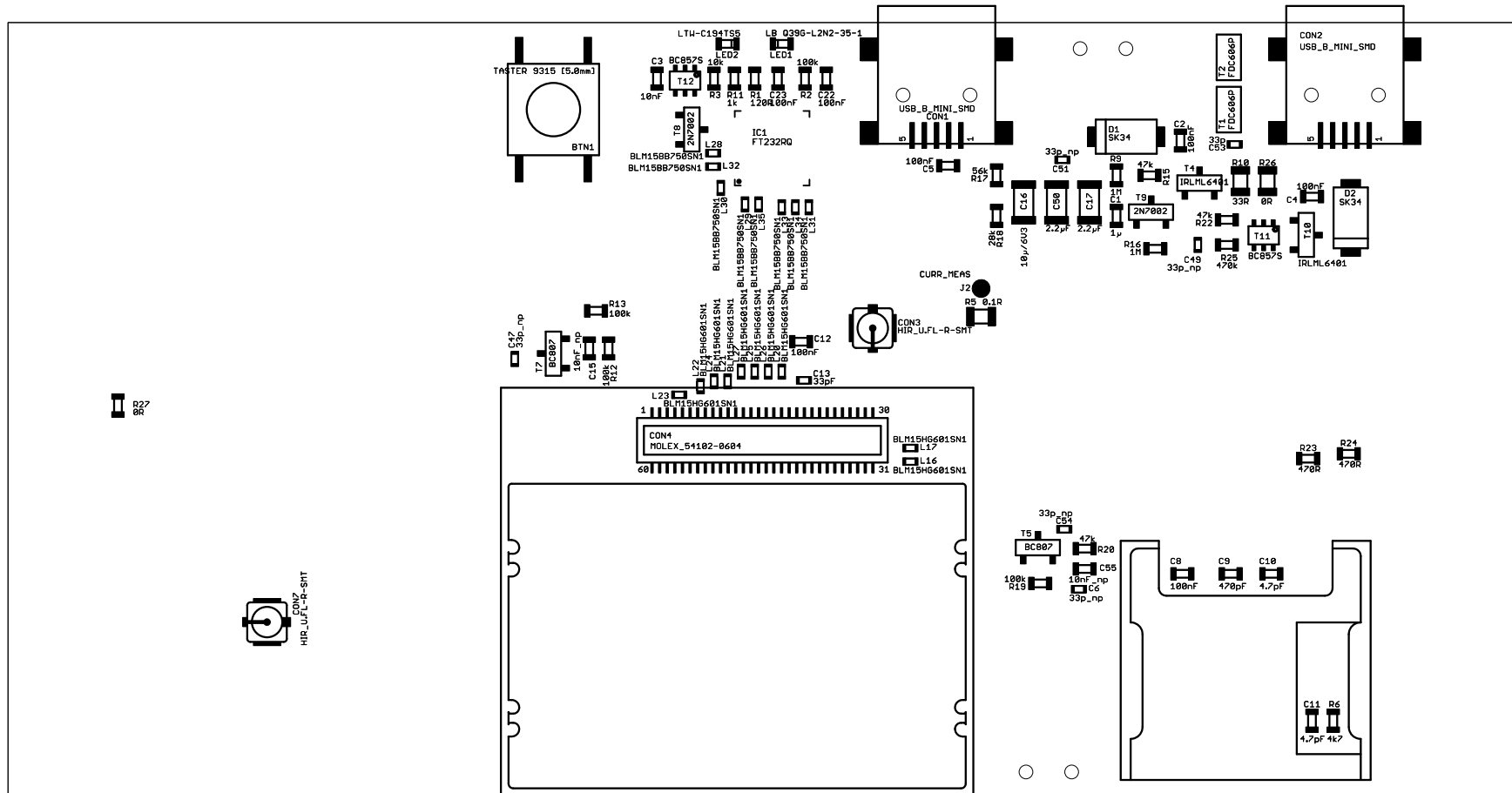

Figure 12: Placement, Page 1 (top)

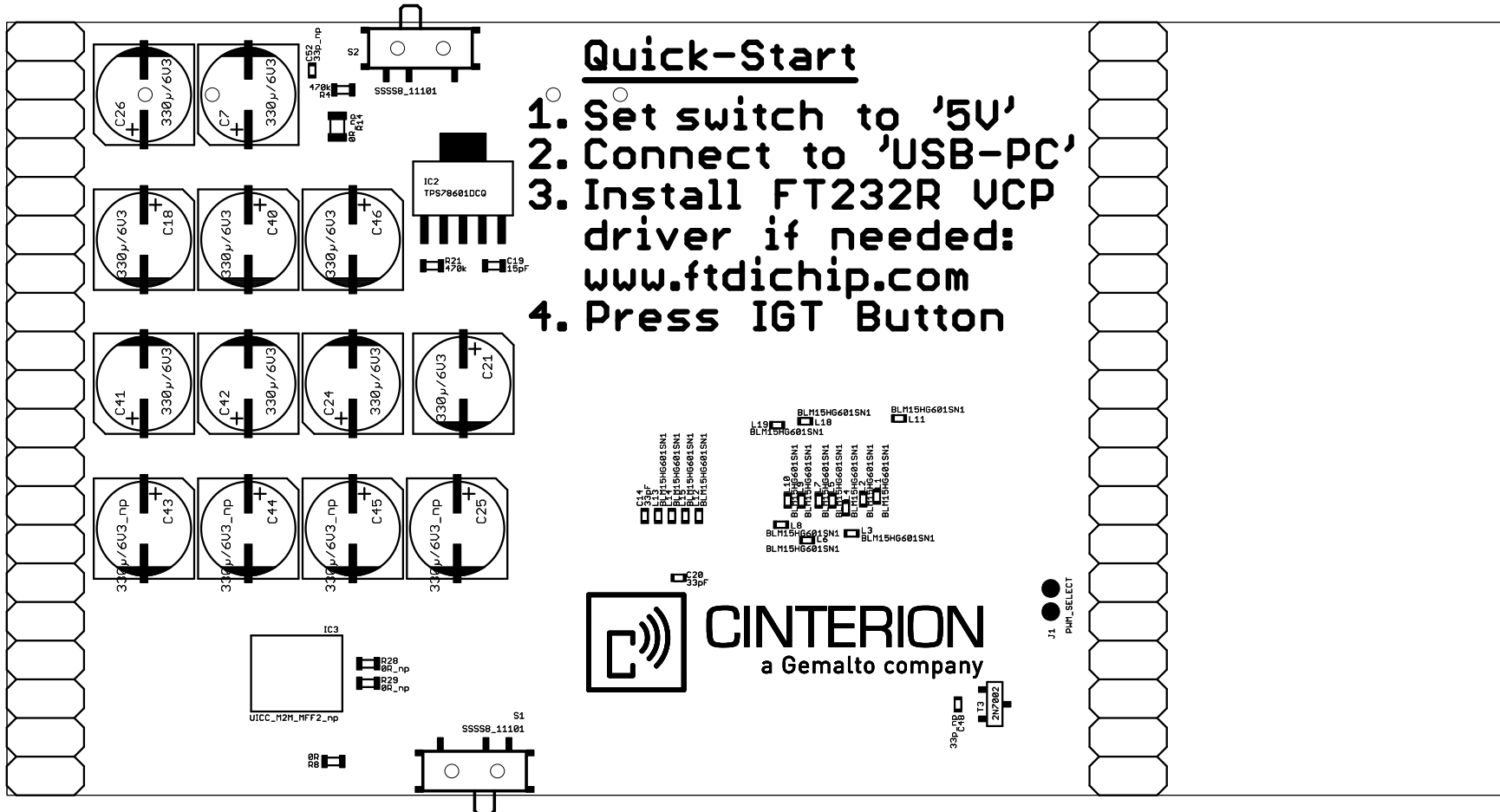

Figure 13: Placement, Page 2 (bottom)