

WiMOD - Demo Board

User Guide

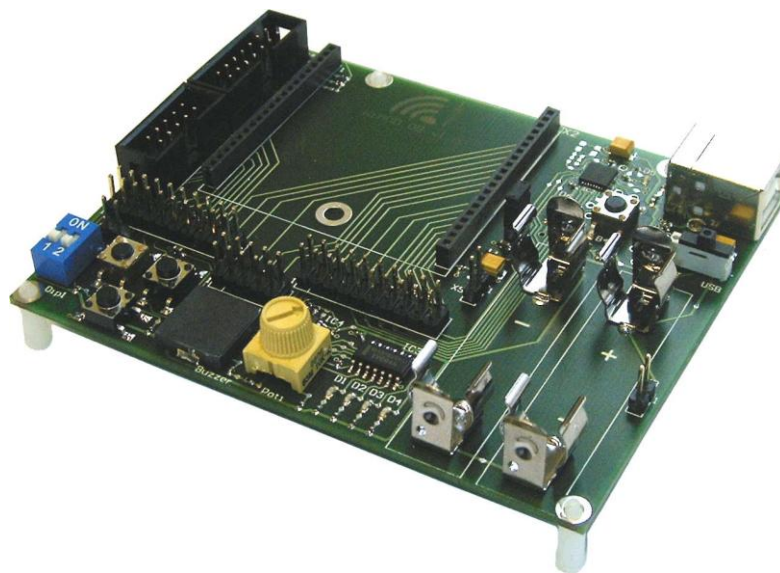

Document ID: 4100/6404/0012

IMST GmbH

Carl-Friedrich-Gauss-Str. 2

D-47475 Kamp-Lintfort



Document Information

File name	DemoBoard_UserGuide
Created	2009-01-15
Total pages	23

Revision History

Version	Description
1.0	Released version.
1.1	Updated Table 4-2 and Table 4-3 (updated version of AB_02 to 2v0).
1.2	Updated Chapter 4 (added adapter board AB_04 for radio module iM860A).
1.3	Updated Table 4-2 and Table 4-3 (updated version of AB_04 to 1v0, previous version 0v1 is not supported any more).
1.4	Added information concerning radio module iM871A. Deleted all sections regarding iM200A Updated Chapter 4 with a new version of AB_01 (now it supports the iM860A). AB_04 is not supported any more. Updated Chapter 5 with schematic version 1.1 (changed values of R20 to R24).
2.0	Added information concerning radio module iM222A. Updated Chapter 4 with AB_05. Adapter Board "Wireless M-Bus AB 1 v1.0" is not supported any more. Modifications to document format and layout. Added chapter 6, and 7.
2.1	Added current measurement notice
2.2	Added information concerning radio modules iM170A and iM880A.
2.3	Added information concerning radio modules iM880B.
2.4	Added information concerning radio modules iM881A.

Aim of this Document

The aim of this document is to give a detailed product description including interfaces, features and functionalities of the WiMOD Demo Board.

Table of Contents

1	SUMMARY / INTRODUCTION	4
1.1	Key Features	4
1.2	Supported Radio Modules	4
2	FUNCTIONAL OVERVIEW	5
2.1	Power Supply	6
2.2	USB Interface	7
2.3	User Interface	7
3	CONNECTORS	9
3.1	Radio Module Connector X1 and X2	9
3.2	I/O Connector X5, X6 and X7	11
3.3	Programming Connector X3 and X4	13
3.4	Power Connector X8, X9 and X10	14
4	ADAPTER BOARD DESCRIPTION	15
5	DEMO BOARD DETAILS	18
5.1	Schematic	18
6	APPENDIX	20
6.1	List of Abbreviations	20
6.2	List of Figures	21
6.3	List of Tables	21
6.4	References	21
7	REGULATORY COMPLIANCE INFORMATION	22
8	IMPORTANT NOTICE	23
8.1	Disclaimer	23
8.2	Contact Information	23

1 Summary / Introduction

The Demo Board belongs to the product family WiMOD and is part of the WiMOD Starter Kit. It provides a basic platform for using and testing the WiMOD radio modules together with several sample applications. Thus it can be used to evaluate all WiMOD radio modules and find out their capabilities.

1.1 Key Features

- Basic platform for using and testing the different WiMOD radio modules
- USB interface for communication with a PC
- Power supply by USB or battery
- 3 push buttons and 2 DIP switches
- 4 LED indicators
- Temperature sensor with 2-Wire Serial Interface
- Buzzer and potentiometer
- Expansion port (I/O connectors)

1.2 Supported Radio Modules

The Demo Board currently supports the following radio modules:

- iM170A
- iM201A
- iM221A
- iM222A
- iM240A
- iM820A
- iM860A
- iM871A
- iM880A, iM880B
- iM881A

To use one of the radio modules in combination with the Demo Board, the module has to be soldered on the corresponding Adapter Board (see chapter 4).

2 Functional Overview

The WiMOD Demo Board provides several functional units and can be used to demonstrate and evaluate the different WiMOD radio modules. The desired radio module must be soldered on its specific Adapter Board (see chapter 4) which can be plugged on the Demo Board.

All functional units of the Demo Board are shown in Figure 2-1. These are the power supply unit (via USB or battery), the user interfaces (USB, led, button, buzzer, potentiometer, sensor), the expansion header (RM connector) for the Adapter Board, and the I/O connectors. The Demo Board user interfaces and most pins of the attached radio module are made available via the I/O connectors. Therefore it is possible to connect the radio module to the user interface by using jumpers or connecting cables. Furthermore it is possible to connect external target boards, sensors or test equipment to these connectors.

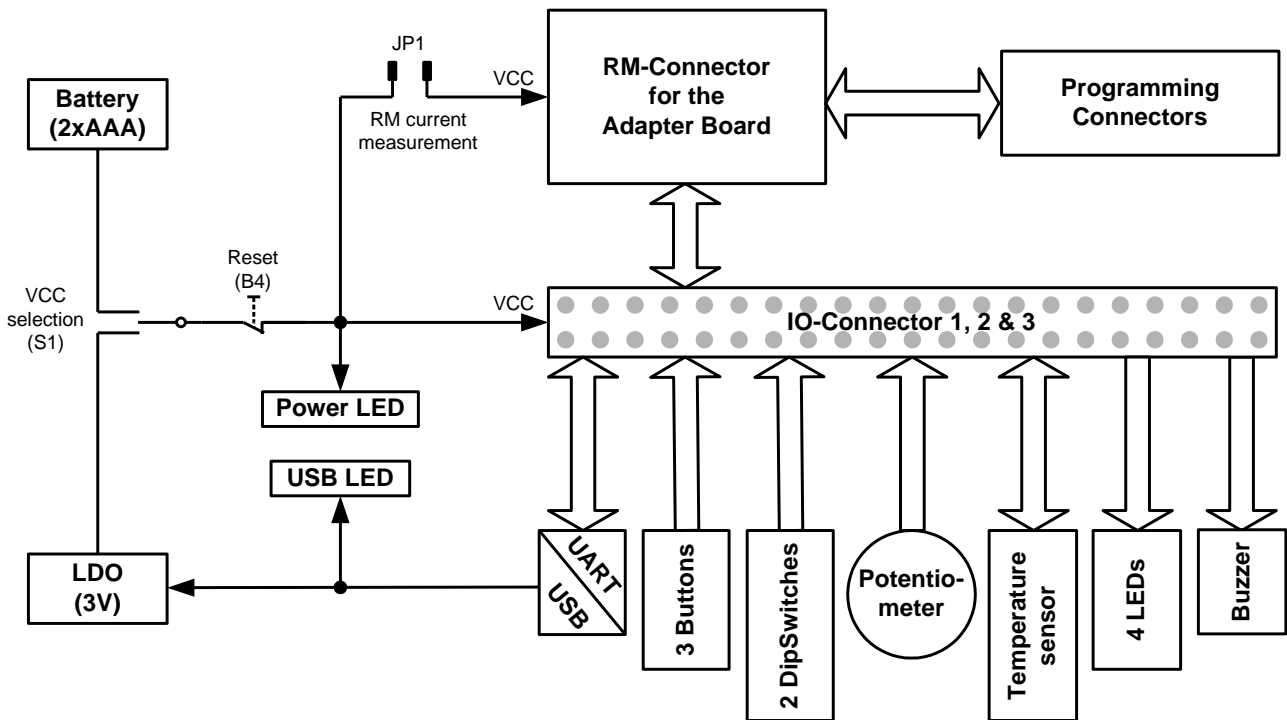

Figure 2-1: Block Diagram of the Demo Board

In the following chapters the functional units are described in detail. Figure 2-2 represents the most important components and their position on the Demo Board. For the schematic of the Demo Board see chapter 5.1.

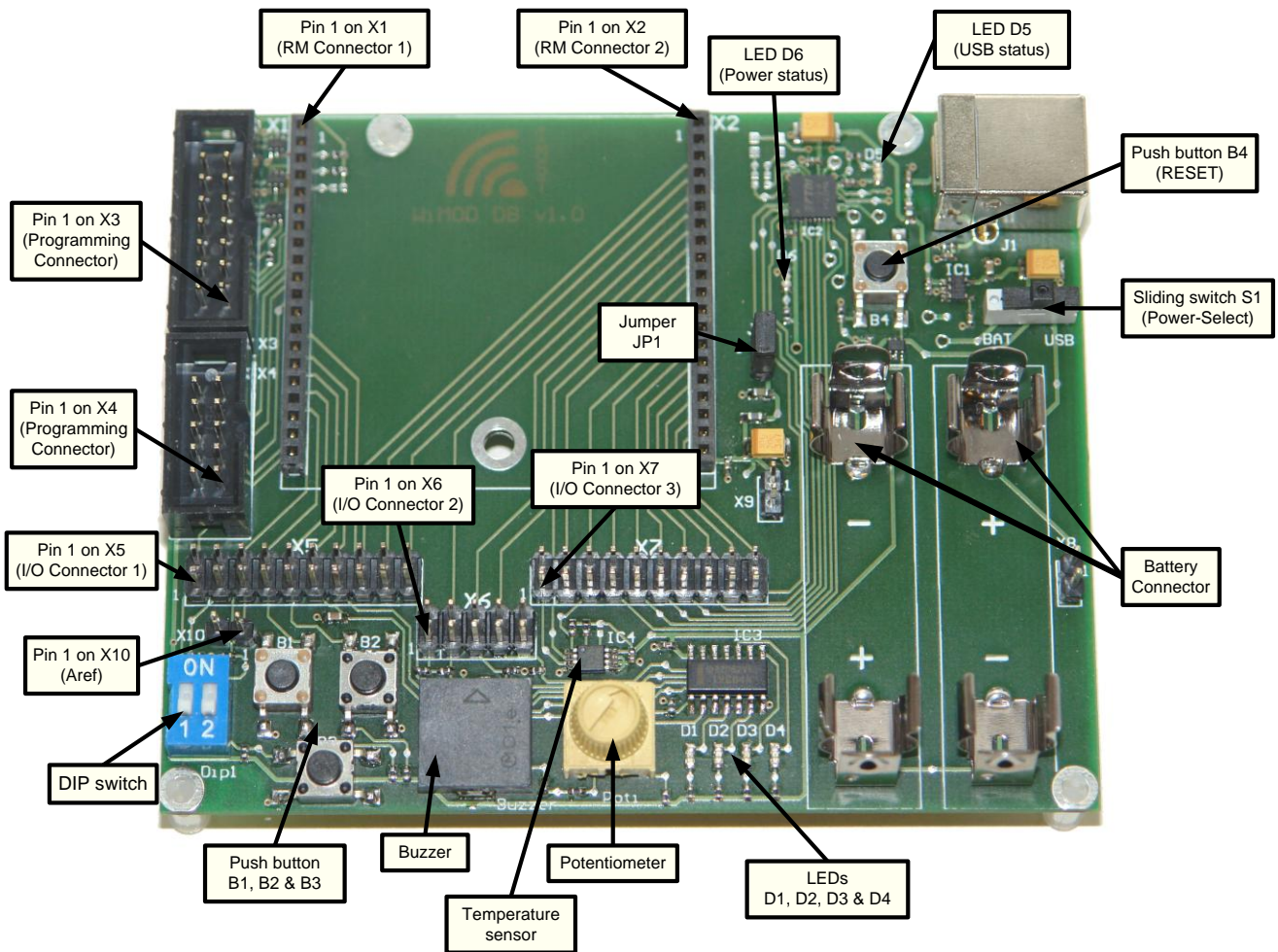

Figure 2-2: Functional Units of the Demo Board

2.1 Power Supply

The Demo Board and the attached radio module may be powered from either two “AAA” size batteries or from the USB bus when connected to a USB port on a PC. The sliding switch S1 toggles between these power sources and must be switched to the wanted power source. In position “USB” the USB bus voltage together with a voltage regulator (3 V) is used. In position “BAT” the battery voltage is used directly. LED 6 is turned on when the Demo Board is powered on. Additionally LED 5 is turned on if a USB connection to a PC is established. It is recommended either to use the battery or the USB power, thus S1 can be used as on-off-switch.

To supply the radio module with power jumper JP1 must be set. Furthermore it can be replaced by an ampere meter to measure the current of the radio module. Note: Some adapter boards are equipped with a boost converter to increase the radio modules supply voltage (e.g. iM871A AB_05). In this cases the current measurement has to be done directly on the adapter board.

Power supply of the Demo Board (except the USB interface) and the attached radio module is interrupted if push button B4 is pressed. Because all radio modules have a Power-On-Reset (POR) functionality B4 serves as the “RESET” button.

2.2 USB Interface

The USB interface of the Demo Board can be used for communication between the attached radio module and a PC. The USB controller (FT232RQ) is turned on once the connection to a PC is established. This is also signaled by LED 5. The USB interface supports "USB 1.1" and "USB 2.0 full speed" modes.

The UART interface (TxD, RxD, /CTS, /RTS, /DSR, /DTR, /Ri) of the used USB controller is available on I/O connector 3 (see chapter 3.2).

Before the USB interface can be used for the first time, the desired hardware driver for the USB controller must be installed on the PC. If the PC will detect the Demo Board as new hardware please follow the given instructions to install the new virtual COM port.

For more information see the corresponding website from FTDI [1].

2.3 User Interface

The user interface of the Demo Board provides the following functionalities. Most of them are available on the I/O connectors (see chapter 3.2).

- USB interface for a serial communication
- LEDs and a buzzer for signal indication
- Buttons and switches for user interaction
- Potentiometer as analog input signal
- Temperature sensor with I²C interface

The Demo Board has six LEDs to indicate a status or an event. Table 2-1 explains the LEDs and to which connector they are connected to.

LED		Available on	Description
D1	red	X5.17 ; X5.19	Useable by the attached radio module.
D2	yellow	X6.3	Useable by the attached radio module.
D3	green	X6.5	Useable by the attached radio module.
D4	orange	X6.7	Useable by the attached radio module.
D5	blue	-	USB status LED, indicating an established USB connection to a PC.
D6	green	-	Power status LED, indicating when power is switched on

Table 2-1: Connections of the LEDs

LED D5 is turned on if a USB connection to a PC is established. LED D6 indicates the power supply status. The LEDs D1 to D4 can be connected to the attached radio module by using jumpers or connecting cables on the I/O connector. They are switched on by a high level signal.

The Demo Board has one sliding switch, four push buttons and two DIP switches. Table 2-2 highlights the functions of these switches and buttons and their availabilities.

Button/Switch	Available on	Description
S1 – Sliding switch	-	Power select switch.
B1 – Push-Button	X5.7	Useable by the attached radio module.
B2 – Push-Button	X5.9	Useable by the attached radio module.
B3 – Push-Button	X5.1	Useable by the attached radio module.
B4 – Push-Button	-	Power-On-RESET switch (interrupts the power supply).
Dip1_1 – DIP switch 1	X5.3	Useable by the attached radio module.
Dip1_2 – DIP switch 2	X5.15	Useable by the attached radio module.

Table 2-2: Connections of Switches and Buttons

Sliding switch S1 selects the power supply (BAT or USB) and button B4 interrupts the power supply when pressed.

The push buttons B1 to B3 and the DIP switches Dip1_1 and Dip1_2 can be connected to the attached radio module by using jumpers or connecting cables on the I/O connectors. All of them have a pull-up resistor and pushing a button or shifting a DIP switch to position ON causes the corresponding pin on the I/O connector to be pulled to GND (falling edge) while releasing will result in a signal with VCC level.

Other units of the Demo Board are explained in Table 2-3. They can be connected to the attached radio module by using jumpers or connecting cables on the I/O connectors.

Function	Available on	Description
Potentiometer	X5.11	Variable resistor
Buzzer	X5.13	Buzzer
Temperature Sensor	Thermostat Output	Thermostat Output Open Drain of the temperature sensor (IC4)
	Sensor_SDA	Data input/output line for 2-Wire serial communication port of the temperature sensor (IC4)
	Sensor_SCL	Clock input line for 2-wire serial communication port of the temperature sensor (IC4).

Table 2-3: Connections of other Functional Units

The potentiometer (trim-pot) provides an analog (voltage) input signal. The value is between GND and approx. 0.7 V.

The buzzer is a piezoelectric sounder and must be externally driven by a signal. Frequency of this signal must be between 2 kHz and 4 kHz.

The temperature sensor DS75LX is a digital thermometer and thermostat. It measures temperatures from -55 °C to +125 °C. Resolution of the digital output signal is 9 to 12 bits. Communication is achieved through a simple 2-Wire Serial Interface (SDA and SCL).

3 Connectors

This chapter describes the different connectors of the Demo Board. These are the RM connector (X1, X2), the I/O connector (X5, X6, X7), the Programming connector (X3, X4) and the Power connector (X8, X9, X10).

3.1 Radio Module Connector X1 and X2

The Radio Module (RM) connector is an expansion header for the Adapter Board and its soldered radio module. The RM connector consists of the two single row header X1 (RM connector 1) and X2 (RM connector 2). Both have 20 pins and a pin pitch of 2.0 mm.

The pinout of X1 and X2 is explained in Table 3-1 and Table 3-2.

Pin-Nr.	Connected to	Description
X1.1	GND	
X1.2	T2.3	/MOSI – inverted programming line of the RS232 programming interface, which is not supported any longer.
X1.3	T3.6	/SCK – inverted clock line of the RS232 programming interface, which is not supported any longer.
X1.4	T2.6	/CS – inverted chip select line of the RS232 programming interface which is not supported any longer.
X1.5	X4.9	MOSI – programming line for ISP
X1.6	X4.8	DC – clock line for the Debug Interface
X1.7	X4.6	/RESET – /RESET line or programming line for DebugWIRE
X1.8	GND	
X1.9	X4.5	DD – data line for the Debug Interface
X1.10	X4.3	MISO – programming line for ISP
X1.11	X4.1	SCK – clock line for ISP
X1.12	X5.14	Connected to I/O connector 1
X1.13	GND	
X1.14	X5.12	Connected to I/O connector 1
X1.15	X5.10	Connected to I/O connector 1
X1.16	X5.8	Connected to I/O connector 1
X1.17	X5.6	Connected to I/O connector 1
X1.18	X5.4	Connected to I/O connector 1
X1.19	X5.2	Connected to I/O connector 1
X1.20	GND	

Table 3-1: Pinout of X1

The pins X1.2, X1.3, and X1.4 are connected to the RS232 programming interface which is not supported any longer. The pins X1.5, X1.6, X1.7, X1.9, X1.10 and X1.11 are connected to X4 which can be used for programming the WiMOD radio modules. All other pins of X1 are connected to GND or to I/O connector 1.

Pin-Nr.	Connected to	Description
X2.1	GND	
X2.2	X5.16	Connected to I/O connector 1
X2.3	X5.18	Connected to I/O connector 1
X2.4	X5.20	Connected to I/O connector 1
X2.5	X6.4	Connected to I/O connector 2
X2.6	X6.6	Connected to I/O connector 2
X2.7	X6.8	Connected to I/O connector 2
X2.8	X7.2	Connected to I/O connector 3
X2.9	X7.4	Connected to I/O connector 3
X2.10	GND	
X2.11	X7.6	Connected to I/O connector 3
X2.12	X7.8	Connected to I/O connector 3
X2.13	X7.10	Connected to I/O connector 3
X2.14	X7.12	Connected to I/O connector 3
X2.15	X7.14	Connected to I/O connector 3
X2.16	X7.16	Connected to I/O connector 3
X2.17	X7.18	Connected to I/O connector 3
X2.18	X7.20	Connected to I/O connector 3
X2.19	GND	
X2.20	VCC_RM	Power supply for the radio module

Table 3-2: Pinout of X2

All pins of X2 are connected to I/O connector 2 and 3 or have to be used for power supply (GND or VCC) of the radio module.

3.2 I/O Connector X5, X6 and X7

The I/O connector consists of the three pin rows X5 (I/O connector 1), X6 (I/O connector 2) and X7 (I/O connector 3). On the one side (odd pin numbers) they are connected to the user interface of the Demo Board. On the other side (even pin numbers) they are connected to the attached radio module via RM connector 1 and 2. Thus it is possible to connect the radio module to the user interface by using jumpers or connecting cables. Figure 3-1 depicts the pinout of the I/O connector.

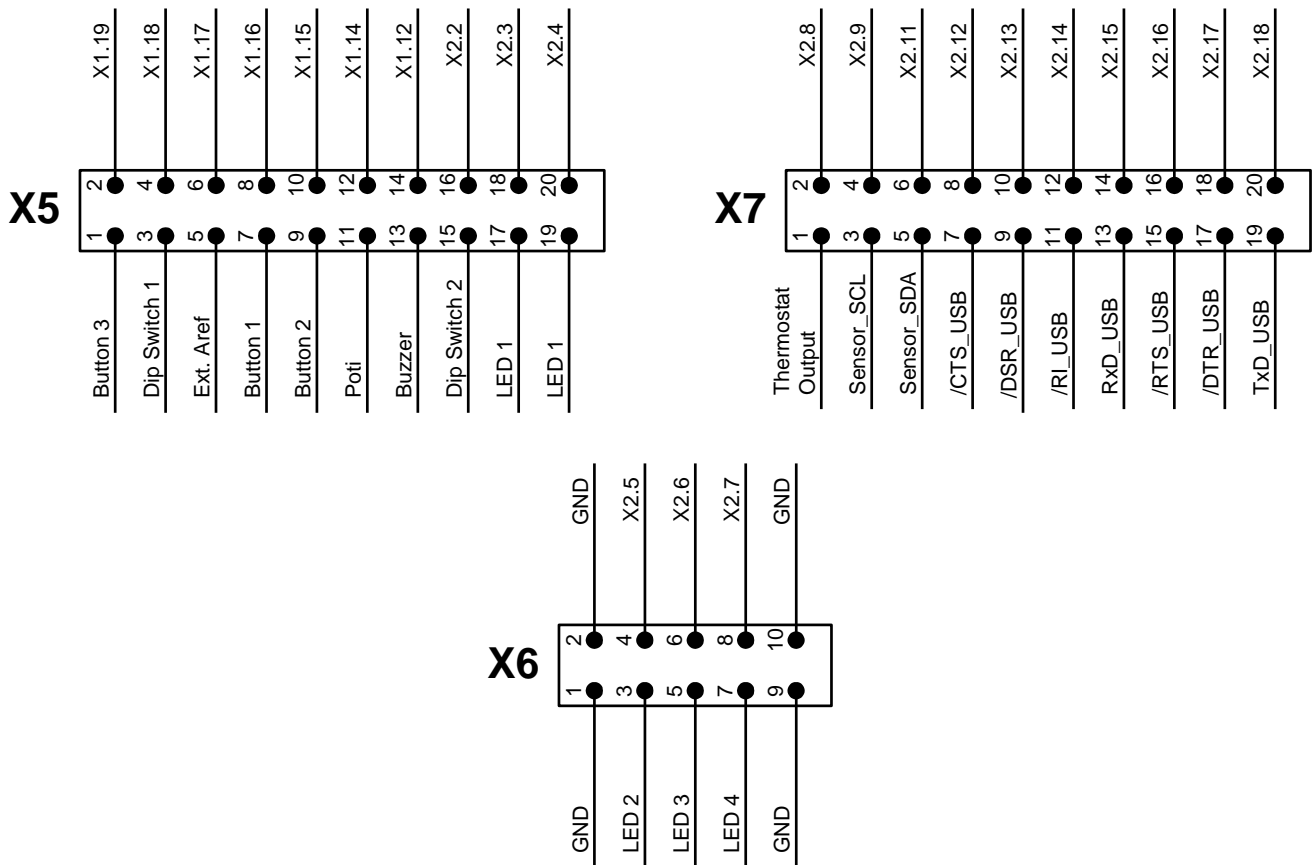

Figure 3-1: Graphical Pinout of the I/O connector

Moreover Table 3-3, Table 3-4, and Table 3-5 explain the pin assignment of the I/O connector.

Pin-Nr.	Connected to	Pin-Nr.	Connected to
X5.1	Button 3	X5.2	X1.19
X5.3	DIP Switch 1	X5.4	X1.18
X5.5	Ext. Aref	X5.6	X1.17
X5.7	Button 1	X5.8	X1.16
X5.9	Button 2	X5.10	X1.15
X5.11	Potentiometer (0 – approx. 0.7V)	X5.12	X1.14
X5.13	Buzzer	X5.14	X1.12
X5.15	DIP Switch 2	X5.16	X2.2
X5.17	LED 1	X5.18	X2.3
X5.19	LED 1	X5.20	X2.4

Table 3-3: Pinout of X5 (I/O connector 1)

Pin-Nr.	Connected to	Pin-Nr.	Connected to
X6.1	GND	X6.2	GND
X6.3	LED 2	X6.4	X2.5
X6.5	LED 3	X6.6	X2.6
X6.7	LED 4	X6.8	X2.7
X6.9	GND	X6.10	GND

Table 3-4: Pinout of X6 (I/O connector 2)

Pin-Nr.	Connected to	Pin-Nr.	Connected to
X7.1	Thermostat Output	X7.2	X2.8
X7.3	Temperature sensor (Sensor_SCL)	X7.4	X2.9
X7.5	Temperature sensor (Sensor_SDA)	X7.6	X2.11
X7.7	IC2.8 – /CTS of the USB Controller	X7.8	X2.12
X7.9	IC2.6 – /DSR of the USB-Controller	X7.10	X2.13
X7.11	IC2.3 – /RI of the USB-Controller	X7.12	X2.14
X7.13	IC2.2 – RxD of the USB-Controller	X7.14	X2.15
X7.15	IC2.32 – /RTS of the USB-Controller	X7.16	X2.16
X7.17	IC2.31 – /DTR of the USB-Controller	X7.18	X2.17
X7.19	IC2.30 – TxD of the USB-Controller	X7.20	X2.18

Table 3-5: Pinout of X7 (I/O connector 3)

3.3 Programming Connector X3 and X4

All modules can be reprogrammed either by using the integrated programming interface or the integrated bootloader via UART interface. On the Demo Board the UART has to be connected to the USB interface on X7. Alternatively the integrated programming interface of the module can be used to flash a new program into the module.

Warning: The bootloader will be deleted if the integrated programming interface is used. It is not possible to update the modules firmware with the corresponding PC tool if the bootloader has been deleted.

Connector X4 can be used to connect a programming device for all WiMOD radio modules (except iM871A which has to be programmed via the programming connector on its Adapter Board "Wireless M-Bus AB 1"). The necessary programming device depends on the connected radio module. Table 3-6 shows the pinout of X4.

Pin-Nr.	Connected to	Description
X4.1	X1.11	SCK – clock line for ISP
X4.2	GND	
X4.3	X1.10	MISO – data line for ISP (to the programming device)
X4.4	VCC	Reference voltage for the programming device. Must not be used to power the Demo Board and the attached radio module.
X4.5	X1.9	DD – data line for the Debug Interface
X4.6	X1.7	/RESET – Reset line for ISP or data line for DebugWIRE
X4.7	NC	Not connected
X4.8	X1.6	DC – clock line for the Debug Interface
X4.9	X1.5	MOSI – data line for ISP (to the radio module)
X4.10	GND	

Table 3-6: : Pinout of X4 (ISP, DebugWIRE, DebugInterface)

Warning: It cannot be guaranteed, that the chosen programming device can be connected one-to-one to programming connector X4. Contact us for further information.

3.4 Power Connector X8, X9 and X10

The connectors X8, X9, and X10 can be used for voltage measurement or to connect an external voltage supply. Voltage of the radio module can be measured on X9. X8 can be used to connect an external voltage (max. 3.6V) instead of the two batteries. For detailed information see the schematic in chapter 5.1. X10 serves as analog reference voltage for the A/D converter of the attached radio module. The usable reference voltage value depends on the used radio module (see the appropriate datasheet).

Warning: Please do not connect a jumper to one of the power connectors. This would cause a short-circuit and could damage the Demo Board and the attached radio module.

4 Adapter Board Description

For using a radio module with the Demo Board and its features, a specific Adapter Board is necessary. It is a carrier board for the radio module which has to be plugged on the RM connector (X1 and X2) of the Demo Board. Figure 4-1 shows an Adapter Board with a soldered radio module.

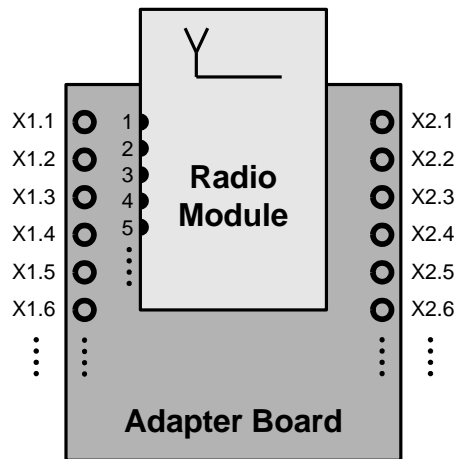

Figure 4-1: Adapter Board with Soldered Radio Module

There are several Adapter Boards for the different radio modules. Table 4-1 explains which radio modules are supported. AB_03 and AB_04 are not supported any more.

Adapter Board	Supported Radio Modules
AB_01	iM201A, iM240A, iM860A, iM170A, iM880A, iM880B, iM881A
AB_02	iM820A, iM221A, iM222A
AB_05	iM871A

Table 4-1: Assignment between WiMOD Modules and Adapter Boards

The following tables (Table 4-2 and Table 4-3) explain the pin assignment of the Adapter Boards respectively the pin assignment of the RM connector (X1 and X2) if the Adapter Board is plugged on the Demo Board. The "Pad Nr." relates to the pads of the soldered radio module.

All Adapter Boards consist of a SMA connector which is connected to the 50 Ω pad of the radio module. It can be used for connecting RF measurement equipment or an external antenna. In this case the RF path of a radio module has to be switched to the 50 Ω pad instead of using the integrated PCB antenna.

X1	AB_01 v2.0 Radio module Pad Nr.	AB_02 v3.0 Radio module Pad Nr.	AB_05 v2.0 Radio module Pad Nr.
X1.1	1/6/11/16/22/ 27/30/32 (GND)	(1/3/4/8/12/16/18/ 19/24/29/33/34 (GND)	5/15/17/24/28 (GND)
X1.2	-	-	-
X1.3	-	-	-
X1.4	-	-	-
X1.5	3	-	-
X1.6	-	32	-
X1.7	7	5 ^{Note 1}	25
X1.8	1/6/11/16/22/ 27/30/32 (GND)	(1/3/4/8/12/16/18/ 19/24/29/33/34 (GND)	5/15/17/24/28 (GND)
X1.9	2	31	-
X1.10	4	-	-
X1.11	5	-	26
X1.12	8	13	-
X1.13	1/6/11/16/22/ 27/30/32 (GND)	(1/3/4/8/12/16/18/ 19/24/29/33/34 (GND)	5/15/17/24/28 (GND)
X1.14	9	20	-
X1.15	12	7	27
X1.16	13	9	4
X1.17	10	28	11
X1.18	15	10	2
X1.19	14	11	14
X1.20	1/6/11/16/22/ 27/30/32 (GND)	(1/3/4/8/12/16/18/ 19/24/29/33/34 (GND)	5/15/17/24/28 (GND)

Notes:
1) There is a RC-filter (1kΩ with 2,7nF) on this line.

Table 4-2: Pinout of X1 with Connected Adapter Board

X2	AB_01 v2.0 Radio module Pad Nr.	AB_02 v3.0 Radio module Pad Nr.	AB_05 v2.0 Radio module Pad Nr.
X2.1	1/6/11/16/22/ 27/30/32 (GND)	(1/3/4/8/12/16/18/ 19/24/29/33/34 (GND)	5/15/17/24/28 (GND)
X2.2	29 ^{Note 2}	6	-
X2.3	29 ^{Note 2}	6	-
X2.4	26 ^{Note 2}	-	1
X2.5	25	30	3
X2.6	24	27	6
X2.7	20	21	7
X2.8	28 ^{Note 1} (GND)	-	-
X2.9	21	15	8
X2.10	1/6/11/16/22/ 27/30/32 (GND)	(1/3/4/8/12/16/18/ 19/24/29/33/34 (GND)	5/15/17/24/28 (GND)
X2.11	23	14	9
X2.12	-	26	-
X2.13	-	-	-
X2.14	-	-	-
X2.15	19	23	19
X2.16	-	25	13
X2.17	-	-	12
X2.18	18	22	18
X2.19	1/6/11/16/22/ 27/30/32 (GND)	(1/3/4/8/12/16/18/ 19/24/29/33/34 (GND)	5/15/17/24/28 (GND)
X2.20	17 (VCC)	17 (VCC)	29 (VCC=3V) ^{Note 3}

Notes:

- 1) Pad 28 of the radio module iM240A is internally connected to GND. Thus X2.8 respectively X7.2 of the Demo Board must not be used when using the iM240A.
- 2) Pad 26 and pad 29 are reserved at the iM240A and should not be connected when using this radio module.
- 3) The radio module is powered by an additional boost converter on the Adapter Board.

Table 4-3: Pinout of X2 with Connected Adapter Board



5 Demo Board Details

5.1 Schematic

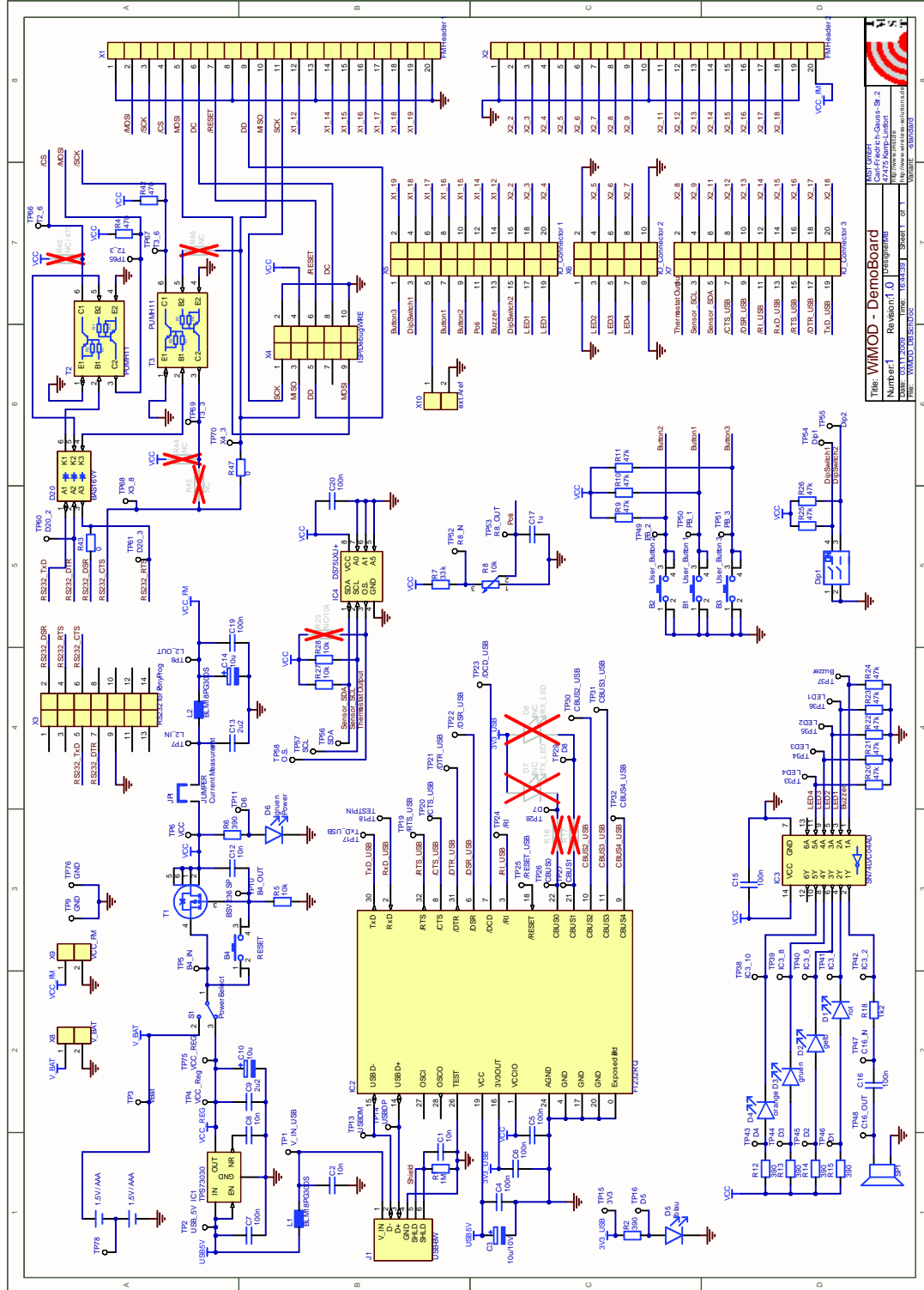

Figure 5-1: Schematic version 1.0 of the Demo Board



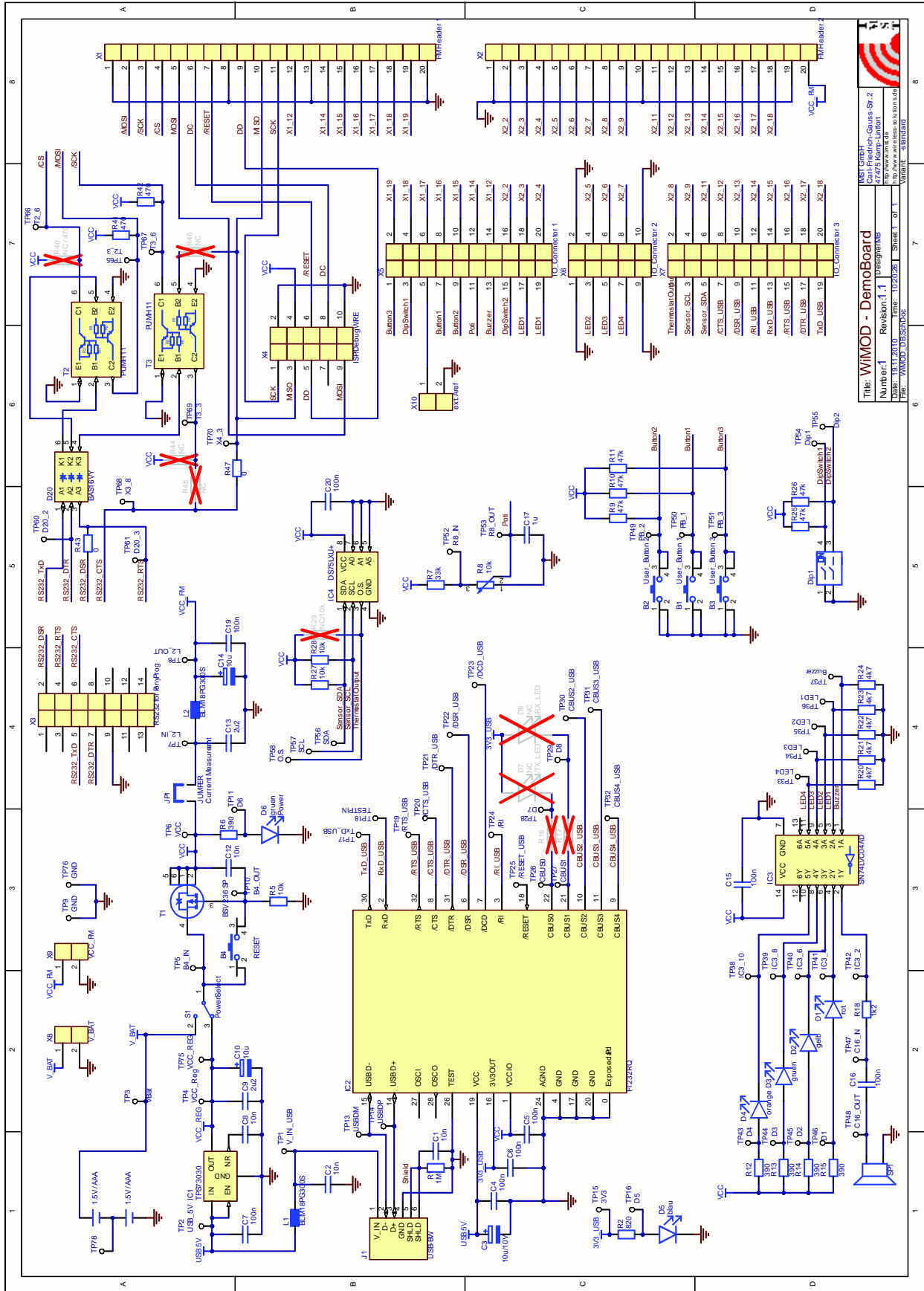

Figure 5-2: Schematic version 1.1 of the Demo Board



6 Appendix

6.1 List of Abbreviations

AB	= Adapter Board
ADC	= Analog-to-Digital Converter
DB	= Demo Board
DIO	= Digital Input/Output
GPIO	= General Purpose Input/Output
IEEE	= Institute of Electrical and Electronics Engineers
I ² C	= Inter-Integrated Circuit
LDO	= Low Drop-Out voltage regulator
MCU	= Microcontroller Unit
PCB	= Printed Circuit Board
POR	= Power-On Reset
RAM	= Random Access Memory
RF	= Radio Frequency
RM	= Radio Module
SPI	= Serial Peripheral interface
UART	= Universal Asynchronous Receiver/Transmitter
USB	= Universal Serial Bus

6.2 List of Figures

Figure 2-1: Block Diagram of the Demo Board	5
Figure 2-2: Functional Units of the Demo Board	6
Figure 3-1: Graphical Pinout of the I/O connector	11
Figure 4-1: Adapter Board with Soldered Radio Module	15
Figure 5-1: Schematic version 1.0 of the Demo Board	18
Figure 5-2: Schematic version 1.1 of the Demo Board	19

6.3 List of Tables

Table 2-1: Connections of the LEDs.....	7
Table 2-2: Connections of Switches and Buttons	8
Table 2-3: Connections of other Functional Units	8
Table 3-1: Pinout of X1	9
Table 3-2: Pinout of X2	10
Table 3-3: Pinout of X5 (I/O connector 1).....	12
Table 3-4: Pinout of X6 (I/O connector 2).....	12
Table 3-5: Pinout of X7 (I/O connector 3).....	12
Table 3-6: : Pinout of X4 (ISP, DebugWIRE, DebugInterface).....	13
Table 4-1: Assignment between WiMOD Modules and Adapter Boards	15
Table 4-2: Pinout of X1 with Connected Adapter Board	16
Table 4-3: Pinout of X2 with Connected Adapter Board	17

6.4 References

- [1] <http://www.ftdichip.com/FTPProducts.htm#FT232R>, FTDI Ltd.

7 Regulatory Compliance Information

The Demo Board is a test/development platform and has not been designed to be embedded into other products (referred as “final products”). It does not fall within the scope of the European Union directives regarding electromagnetic compatibility, restricted substances (RoHS), recycling (WEEE), FCC, CE or UL, and therefore may not meet the technical requirements of these directives or other related directives.

The Demo Board is intended for use only in a laboratory test environment. All persons handling the Demo Board must be properly trained in electronics and observe good engineering practice standards.

8 Important Notice

8.1 Disclaimer

IMST GmbH points out that all information in this document is given on an “as is” basis. No guarantee, neither explicit nor implicit is given for the correctness at the time of publication. IMST GmbH reserves all rights to make corrections, modifications, enhancements, and other changes to its products and services at any time and to discontinue any product or service without prior notice. It is recommended for customers to refer to the latest relevant information before placing orders and to verify that such information is current and complete. All products are sold and delivered subject to “General Terms and Conditions” of IMST GmbH, supplied at the time of order acknowledgment.

IMST GmbH assumes no liability for the use of its products and does not grant any licenses for its patent rights or for any other of its intellectual property rights or third-party rights. It is the customer’s duty to bear responsibility for compliance of systems or units in which products from IMST GmbH are integrated with applicable legal regulations. Customers should provide adequate design and operating safeguards to minimize the risks associated with customer products and applications. The products are not approved for use in life supporting systems or other systems whose malfunction could result in personal injury to the user. Customers using the products within such applications do so at their own risk.

Any reproduction of information in datasheets of IMST GmbH is permissible only if reproduction is without alteration and is accompanied by all given associated warranties, conditions, limitations, and notices. Any resale of IMST GmbH products or services with statements different from or beyond the parameters stated by IMST GmbH for that product/solution or service is not allowed and voids all express and any implied warranties. The limitations on liability in favor of IMST GmbH shall also affect its employees, executive personnel and bodies in the same way. IMST GmbH is not responsible or liable for any such wrong statements.

Copyright © 2009, IMST GmbH

8.2 Contact Information

IMST GmbH

Carl-Friedrich-Gauss-Str. 2
47475 Kamp-Lintfort
Germany

T +49 2842 981 0 E wimod@imst.de
F +49 2842 981 299 I www.wireless-solutions.de